





# MESSAGE FROM THE PRESIDENT



Dear Customer,

Welcome to **Penroyer-Dodge Company!** You are about to meet a family owned company that has been in the Precision Gage business since 1948. **Penroyer-Dodge Company** is a leader in the manufacturing of all types of precision thread and cylindrical gages, as well as the design and manufacturing of special fixture gaging.

The basic philosophy of **Penroyer-Dodge Company** has always been that our customers deserve our best effort. We know that quality and confidence is a prime concern in this competitive market.

The following pages will introduce you to consider the capabilities of our staff and our history of quality gaging as it relates to your individual problem areas.

If you are already a customer, we would like to take this opportunity to thank you for your patronage. **Penroyer-Dodge Company** values the opportunity to continue serving you for all your gaging needs.

  
Hazel L. Dodge

  
Robert Dodge

## SALES AND SERVICE

When you buy from **Penroyer-Dodge Company** you're buying proven quality and reliability. Our knowledgeable sales and engineering staff offer expert phone service in sales and technical information. We invite you to phone our Toll Free Number (**1-800-736-4243**) and let our staff assist you with your gaging requirements.

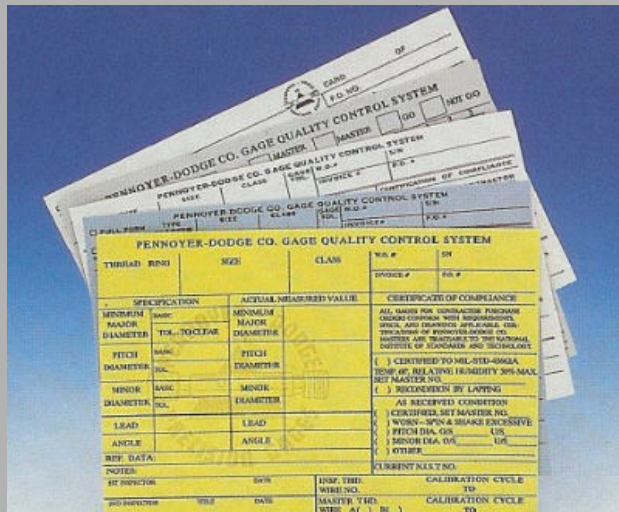

## QUALITY CONTROL

**Penroyer-Dodge Company** maintains a strict quality control program to insure the accuracy of its measurements. There is an in-process surveillance throughout the manufacturing process that insures the quality of our product. Final inspection is performed on all gauges by trained technicians in our environmentally controlled labs.

All **Penroyer-Dodge Company** final inspection equipment is recalibrated on a designated recall schedule. The accuracy of all our final inspection equipment, measuring blocks and thread wires, are traceable to N.I.S.T. **Penroyer-Dodge Company** maintains a quality control manual which adheres to the most stringent government requirements.

## CALIBRATION AND RECONDITIONING SERVICE

To aid customers in the calibration requirements of ISO 10012-1, ANSI/NCSS Z540-1, Mil-Std-45662A, **Penroyer-Dodge Company** supplies complete certificates of calibration for all gages traceable to N.I.S.T. These certificates contain basic as well as actual measured values. Used gage certifications show not only the as-found values, but if reconditioned, we also include the new in-tolerance values. Sizable cost and time saving can be achieved through this reconditioning process.





# Pennoyer-Dodge Co.

## Welcome to Pennoyer-Dodge Company!

### SALES AND SERVICE

When you buy from **Pennoyer-Dodge Company** you're buying proven quality and reliability. Our knowledgeable sales and engineering staff offer expert phone service in sales and technical information. We invite you to phone our Toll Free Number (**1-800-736-4243**) and let our staff assist you with your gaging requirements.

### CALIBRATION AND RECONDITIONING SERVICE

To aid customers in the calibration requirements of ISO 10012-1, ANSI/NC SL Z540-1, Mil-Std-45662A, **Pennoyer-Dodge Company** supplies complete certificates of calibration for all gages traceable to N.I.S.T. These certificates contain basic as well as actual measured values. Used gage certifications show not only the as-found values, but if reconditioned, we also include the new in-tolerance values. Sizable cost and time saving can be achieved through this reconditioning process.

### QUALITY CONTROL

**Pennoyer-Dodge Company** maintains a strict quality control program to insure the accuracy of its measurements. There is a in-process surveillance throughout the manufacturing process that insures the quality of our product. Final inspection is performed on all gauges by trained technicians in our environmentally controlled labs.

All **Pennoyer-Dodge Company** final inspection equipment is recalibrated on a designated recall schedule. The accuracy of all our final inspection equipment, measuring blocks and thread wires, are traceable to N.I.S.T. **Pennoyer-Dodge Company** maintains a quality control manual which adheres to the most stringent government requirements.



## Pennoyer-Dodge Company

*When you need it right and right away!*

Accepted Methods of Payment  
COD,

Net 30 days from date of invoice ( upon credit approval ),



### Table of Contents

Expedite Service	4	NPT Taper Pipe Ring & Plug Gages	23
Taperlock Thread Gages	5 - 7	Cylindrical Taperlock Gages	24
Reversible Thread Plug Gages	8	Cylindrical Reversible Gages	25
S.T.I. Thread Plug Gages X-Tolerance	9	Cylindrical Trilock Gages	26
Standard Thread Ring Gages	10 - 11	Cylindrical Progressive Gages	27
Truncated Setting Plug Gages	12 - 14	Cylindrical Ring Gages	28
Progressive Setting Plug Gages	15 - 16	Standard Calibration/Certification Charges	29
Metric Thread Plug Gages	17	Special Gage Listing	30
Metric Reversible Plug Gages	18	Before Plate Formulas	31
Metric Thread Ring Gages	19	Twister Gages	32
Metric Truncated Setting Plug Gages	20	Twister Out	33
NPTF Taper Pipe Ring & Plug Gages	21	Twister In	34
ANPT Taper Pipe Ring & Plug Gages	22		

PRICES SUBJECT TO CHANGE WITHOUT NOTICE 10/11/2018

- 3 -

**PENNOYER-DODGE CO.**

**1-800-736-4243**

818-547-2100

Fax 1-818-240-5719



Pennoyer-Dodge Co.

Our  
**I Need It Now!**

**Expedite Service**

- Where time is of the essence and normal delivery schedules won't do...
- We will be glad to help you with your "just in time" gaging needs...
- Try our **I NEED IT NOW** 24 & 48 hour Expediting Service.
- Call our technical sales staff and let us know your specific requirements.

**1-800-736-4243**

## COMPANY HOURS

**6:00AM to 4:30 PM P.S.T. - MONDAY-FRIDAY  
SATURDAYS 6:00AM TO NOON**

***"WE ARE HERE TO HELP YOU  
WITH ANY GAGING NEEDS"***



# Pennoyer-Dodge Co. Taperlock Thread Plug Gages

American Gage Design / Short & Long Form Calibration Reports Available

## How To Order

1. State Quantity desired.
2. Nominal size and threads per inch and class of fit.  
Example: 1/4-28 UNF-2B
3. Go or Not Go or a complete double end.
4. Handles: Either single end or double end / special marking may be added for

**Call Toll Free  
1-800-736-4243**

- an additional charge. (\$15.00 min). Handles ordered in colors other than Red or Green add \$20.00 per handle.
5. Short Form c of c @ n/c. Long Form Calibration Reports add \$20.00 per member.
  6. Calibration stickers available @ \$5.00 per sticker (advise calibration cycle).
  7. CHROME: Add 50% to each member.
  8. "J" Series thread: Add \$8.00 per plug member.

### CLASS X RIGHT HAND TAPERLOCK THREAD PLUG GAGES

Nominal Size	Go or Not Go 2B or 3B Members	Complete Double End Gage w/Handle	Handle Only	Handle Size
#0-80 UNF	51.00	117.00	15.00	#000
#1-64 UNC	51.00	117.00	15.00	#000
# 1-72 UNF	51.00	117.00	15.00	# 000
# 2-56 UNC	48.00	111.00	15.00	# 000
# 2-64 UNF	48.00	111.00	15.00	# 000
# 3-48 UNC	45.00	105.00	15.00	# 000
# 3-56 UNF	45.00	105.00	15.00	# 000
# 4-40 UNC	41.00	97.00	15.00	# 00
# 4-48 UNF	43.00	101.00	15.00	# 00
# 5-40 UNC	40.00	95.00	15.00	# 00
# 5-44 UNF	42.00	99.00	15.00	# 00
# 6-32 UNC	37.00	89.00	15.00	# 00
# 6-40 UNF	37.00	89.00	15.00	# 00
# 8-32 UNC	37.00	89.00	15.00	# 0
# 8-36 UNF	37.00	89.00	15.00	# 0
# 10-24 UNC	37.00	89.00	15.00	# 0
# 10-32 UNF	37.00	89.00	15.00	# 0
# 12-24 UNC	37.00	89.00	15.00	# 0
# 12-28 UNF	37.00	89.00	15.00	# 0
# 12-32 UNEF	58.00	131.00	15.00	# 0
1/4-20 UNC	36.00	87.00	15.00	# 1
1/4-28 UNF	36.00	87.00	15.00	# 1
1/4-32 UNEF	58.00	131.00	15.00	# 1
5/16-18 UNC	36.00	87.00	15.00	# 1
5/16-24 UNF	36.00	87.00	15.00	# 1
5/16-32 UNEF	58.00	131.00	15.00	# 1
3/8-16 UNC	37.00	89.00	15.00	# 2
3/8-24 UNF	37.00	89.00	15.00	# 2
3/8-32 UNEF	66.00	147.00	15.00	# 2
7/16-14 UNC	37.00	89.00	15.00	# 2
7/16-20 UNF	37.00	89.00	15.00	# 2



PRICES SUBJECT TO CHANGE WITHOUT NOTICE 10/11/2018

- 5 -



# Pennoyer-Dodge Co. Taperlock Thread Plug Gages

American Gage Design / Short & Long Form Calibration Reports Available

## How To Order

1. State Quantity desired.
2. Nominal size and threads per inch and class of fit.  
Example: 1/4-28 UNF-2B
3. Go or Not Go or a complete double end.
4. Handles: Either single end or double end / special marking may be added for

**Call Toll Free**  
**1-800-736-4243**

- an additional charge. (\$15.00 min). Handles ordered in colors other than Red or Green add \$20.00 per handle.
5. Short Form c of c @ n/c. Long Form Calibration Reports add \$20.00 per member.
  6. Calibration stickers available @ \$5.00 per sticker (advise calibration cycle).
  7. CHROME: Add 50% to each member.
  8. "J" Series thread: Add \$8.00 per plug member.

### CLASS X RIGHT HAND TAPERLOCK THREAD PLUG GAGES

Nominal Size	Go or Not Go 2B or 3B Members	Complete Double End Gage w/Handle	Handle Only	Handle Size
7/16-28 UNEF	64.00	143.00	15.00	# 2
1/2-13 UNC	37.00	89.00	15.00	# 2
1/2-20 UNF	37.00	89.00	15.00	# 2
1/2-28 UNEF	67.00	149.00	15.00	# 2
9/16-12 UNC	47.00	109.00	15.00	# 3
9/16-18 UNF	47.00	109.00	15.00	# 3
9/16-24 UNEF	75.00	165.00	15.00	# 3
5/8-11 UNC	47.00	109.00	15.00	# 3
5/8-18 UNF	47.00	109.00	15.00	# 3
5/8-24 UNEF	75.00	165.00	15.00	# 3
11/16-24 UNEF	75.00	165.00	15.00	# 3
3/4-10 UNC	52.00	119.00	15.00	# 3
3/4-16 UNF	52.00	119.00	15.00	# 3
3/4-20 UNEF	76.00	167.00	15.00	# 3
13/16-20 UNEF	85.00	185.00	15.00	# 3
7/8-9 UNC	54.00	123.00	15.00	# 4
7/8-14 UNF	54.00	123.00	15.00	# 4
7/8-20 UNEF	85.00	185.00	15.00	# 4
15/16-20 UNEF	86.00	187.00	15.00	# 4
1-8 UNC	62.00	139.00	15.00	# 4
1-12 UNF	62.00	139.00	15.00	# 4
1-14 UNS	64.00	143.00	15.00	# 4
1-20 UNEF	97.00	209.00	15.00	# 4
1 1/16-18 UNEF	98.00	211.00	15.00	# 4
1 1/8-7 UNC	76.00	167.00	15.00	# 4
1 1/8-12 UNF	76.00	167.00	15.00	# 4
1 1/8-18 UNEF	98.00	211.00	15.00	# 4
1 3/16-18 UNEF	104.00	223.00	15.00	# 5
1 1/4-7 UNC	82.00	179.00	15.00	# 5
1 1/4-12 UNF	82.00	179.00	15.00	# 5
1 1/4-18 UNEF	107.00	229.00	15.00	# 5



PRICES SUBJECT TO CHANGE WITHOUT NOTICE 10/11/2018

- 6 -

**PENNOYER-DODGE CO.**

**1-800-736-4243**

818-547-2100

Fax 1-818-240-5719



# Penroyer-Dodge Co. Taperlock Thread Plug Gages

American Gage Design / Short & Long Form Calibration Reports Available

### How To Order

1. State Quantity desired.
2. Nominal size and threads per inch and class of fit.  
Example: 1/4-28 UNF-2B
3. Go or Not Go or a complete double end.
4. Handles: Either single end or double end / special marking may be added for

**Call Toll Free  
1-800-736-4243**

- an additional charge. (\$15.00 min). Handles ordered in colors other than Red or Green add \$20.00 per handle.
5. Short Form c of c @ n/c. Long Form Calibration Reports add \$20.00 per member.
  6. Calibration stickers available @ \$5.00 per sticker (advise calibration cycle).
  7. CHROME: Add 50% to each member.
  8. "J" Series thread: Add \$8.00 per plug member.

### CLASS X RIGHT HAND TAPERLOCK THREAD PLUG GAGES

Nominal Size	Go or Not Go 2B or 3B Members	Complete Double End Gage w/Handle	Handle Only	Handle Size
1 5/16-18 UNEF	110.00	235.00	15.00	# 5
1 3/8-6 UNC	93.00	201.00	15.00	# 5
1 3/8-12 UNF	93.00	201.00	15.00	# 5
1 3/8-18 UNEF	120.00	255.00	15.00	# 5
1 7/16-18 UNEF	120.00	255.00	15.00	# 5
1 1/2-6 UNC	102.00	219.00	15.00	# 5
1 1/2-12 UNF	102.00	219.00	15.00	# 5
1 1/2-18 UNEF	130.00	275.00	15.00	# 5





# Pennoyer-Dodge Co. Reversible Thread Plug Gages

American Gage Design / Short & Long Form Calibration Reports Available

## How To Order

1. State Quantity desired.
2. Nominal size and threads per inch and class of fit.  
Example: 1/4-28 UNF-2B
3. Go or Not Go or a complete double end.
4. Handles: Either single end or double end.

**Call Toll Free  
1-800-736-4243**

- Handles ordered in colors other than Red or Green collets and other than plain handles, call for current pricing.
5. Special marking may be added for an additional charge. (\$15.00 min).
  6. Short Form c of c @ n/c. Long Form certifications add \$20.00 per member.
  7. Calibration stickers available @ \$5.00 per sticker (advise calibration cycle).
  8. CHROME: Add 50% to each member.
  9. If Trilock style desired, price upon application.

### CLASS X RIGHT HAND REVERSIBLE THREAD PLUGGAGES

Nominal Size	Go or Not Go 2B or 3B Members	Complete Double End Gage w/Handle	Handle Only	Handle Size
# 0-80 UNF	74.00	165.00	17.00	# 1w
# 1-64 UNC	74.00	165.00	17.00	# 1w
# 1-72 UNF	73.00	163.00	17.00	# 1w
# 2-56 UNC	69.00	155.00	17.00	# 2w
# 2-64 UNF	69.00	155.00	17.00	# 2w
# 3-48 UNC	65.00	147.00	17.00	# 2w
# 3-56 UNF	65.00	147.00	17.00	# 2w
# 4-40 UNC	59.00	135.00	17.00	# 2w
# 4-48 UNF	65.00	147.00	17.00	# 2w
# 5-40 UNC	59.00	135.00	17.00	# 2w
# 5-44 UNF	55.00	127.00	17.00	# 2w
# 6-32 UNC	55.00	127.00	17.00	# 2w
# 6-40 UNF	55.00	127.00	17.00	# 2w
# 8-32 UNC	55.00	127.00	17.00	# 2w
# 8-36 UNF	55.00	127.00	17.00	# 2w
# 10-24 UNC	55.00	127.00	17.00	# 3w
# 10-32 UNF	55.00	127.00	17.00	# 3w
# 12-24 UNC	55.00	127.00	17.00	# 3w
# 12-28 UNF	55.00	127.00	17.00	# 3w
1/4-20 UNC	53.00	123.00	17.00	# 3w
1/4-28 UNF	53.00	123.00	17.00	# 3w
5/16-18 UNC	53.00	123.00	20.00	# 4w
5/16-24 UNF	53.00	123.00	20.00	# 4w
3/8-16 UNC	55.00	130.00	20.00	# 4w
3/8-24 UNF	55.00	130.00	20.00	# 4w
7/16-14 UNC	55.00	130.00	20.00	# 5w
7/16-20 UNF	55.00	130.00	20.00	# 5w
1/2-13 UNC	55.00	130.00	20.00	# 5w
1/2-20 UNF	55.00	130.00	20.00	# 5w
9/16-12 UNC	66.00	157.00	25.00	# 6w
9/16-18 UNF	66.00	157.00	25.00	# 6w
5/8-11 UNC	66.00	157.00	25.00	# 6w
5/8-18 UNF	66.00	157.00	25.00	# 6w
3/4-10 UNC	70.00	165.00	25.00	# 7w
3/4-16 UNF	70.00	165.00	25.00	# 7w



PRICES SUBJECT TO CHANGE WITHOUT NOTICE 10/11/2018

- 8 -





# Pennoyer-Dodge Co.

## S.T.I. Thread Plug Gages X-Tolerance

American Gage Design / Short & Long Form Calibration Reports Available

### How To Order

1. State Quantity desired.
2. Nominal size and threads per inch and class of fit.  
Example: 1/4-28 UNF-2B S.T.I.
3. Go or Not Go or a complete double end.
4. Handles: Either single end or double end. Handles ordered in colors other than Red or Green add \$20.00 per handle.

**Call Toll Free**  
**1-800-736-4243**

5. Special marking may be added for an additional charge. (\$15.00 min).
6. Short Form c of c @ n/c. Long Form Calibration Reports add \$20.00 per member.
7. Calibration stickers available @ \$5.00 per sticker (advise calibration cycle).
8. "W" tolerance (Inspection Grade) add 30%. Must purchase long form calibration reports.
9. CHROME: Add 50% to each member.
10. "J" series thread add \$8.00 per plug member.

#### CLASS X RIGHT HAND S.T.I. THREAD PLUG GAGES

Nominal Size	Go Member	2B, 3B Not Go Member	Complete Double End 2B, 3B Gage w/Handle	Handle Only	Handle Size
# 2-56 UNC	59.00	68.00	142.00	15.00	# 00
# 4-40 UNC	57.00	57.00	129.00	15.00	# 00
# 4-48 UNF	52.00	59.00	126.00	15.00	# 00
# 6-32 UNC	49.00	57.00	121.00	15.00	# 0
# 6-40 UNF	52.00	59.00	126.00	15.00	# 0
# 8-32 UNC	51.00	57.00	123.00	15.00	# 0
# 10-24 UNC	51.00	59.00	125.00	15.00	# 0
# 10-32 UNF	51.00	57.00	123.00	15.00	# 0
1/4-20 UNC	50.00	55.00	120.00	15.00	# 1
1/4-28 UNF	50.00	55.00	120.00	15.00	# 1
5/16-18 UNC	50.00	58.00	123.00	15.00	# 2
5/16-24 UNF	50.00	55.00	120.00	15.00	# 1
3/8-16 UNC	51.00	58.00	124.00	15.00	# 2
3/8-24 UNF	51.00	55.00	121.00	15.00	# 2
7/16-14 UNC	56.00	58.00	129.00	15.00	# 3
7/16-20 UNF	51.00	55.00	121.00	15.00	# 2
1/2-13 UNC	54.00	63.00	132.00	15.00	# 3
1/2-20 UNF	54.00	58.00	127.00	15.00	# 3





# Pennoyer-Dodge Co. Standard Thread Rings Gages

American Gage Design / Short & Long Form Calibration Reports Available

### How To Order

1. State Quantity desired.
2. Nominal size and threads per inch and class of fit.  
Example: 1/4-28 UNF-2A
3. Go or Not Go or a set of gages.

**Call Toll Free  
1-800-736-4243**

4. Special marking for an additional charge.(\$15.00 min.)
5. Short Form c of c @ n/c. Long Form Calibration Reports add \$20.00 per member.
6. Calibration stickers available @ \$5.00 per sticker (advise calibration cycle).
7. CHROME: Add 50% for sizes #10 and up, per ring.
8. For "J" series (MIL-S-8879 and SAE-AS-71051), add \$70.00 per GO ring.

CLASS X RIGHT HAND  
AGD THREAD RING GAGES

Nominal Size	Go or Not Go 2A or 3A	Go & Not Go Sets 2A or 3A	Ring Holder	Ring Holder Size
# 0-80 UNF	152.00	304.00	20.00	1T
# 1-64 UNC	142.00	284.00	20.00	1T
# 1-72 UNF	142.00	284.00	20.00	1T
# 2-56 UNC	128.00	256.00	20.00	1T
# 2-64 UNF	128.00	256.00	20.00	1T
# 3-48 UNC	128.00	256.00	20.00	1T
# 3-56 UNF	128.00	256.00	20.00	1T
# 4-40 UNC	118.00	236.00	20.00	1T
# 4-48 UNF	118.00	236.00	20.00	1T
# 5-40 UNC	105.00	210.00	20.00	1T
# 5-44 UNF	105.00	210.00	20.00	1T
# 6-32 UNC	105.00	210.00	20.00	1T
# 6-40 UNF	105.00	210.00	20.00	1T
# 8-32 UNC	101.00	202.00	20.00	1T
# 8-36 UNF	101.00	202.00	20.00	1T
# 10-24 UNC	101.00	202.00	20.00	1T
# 10-32 UNF	101.00	202.00	20.00	1T
# 12-24 UNC	101.00	202.00	20.00	1T
# 12-28 UNF	101.00	202.00	20.00	1T
# 12-32 UNEF	128.00	256.00	20.00	1T
1/4-20 UNC	101.00	202.00	20.00	2T
1/4-28 UNF	101.00	202.00	20.00	2T
1/4-32 UNEF	128.00	256.00	20.00	2T
5/16-18 UNC	99.00	198.00	20.00	2T
5/16-24 UNF	99.00	198.00	20.00	2T
5/16-32 UNEF	128.00	256.00	20.00	2T
3/8-16 UNC	105.00	210.00	20.00	3T
3/8-24 UNF	105.00	210.00	20.00	3T
3/8-32 UNEF	131.00	262.00	20.00	3T
7/16-14 UNC	105.00	210.00	20.00	3T
7/16-20 UNF	105.00	210.00	20.00	3T
7/16-28 UNEF	128.00	256.00	20.00	3T
1/2-13 UNC	107.00	214.00	20.00	3T
1/2-20 UNF	107.00	214.00	20.00	3T
1/2-28 UNEF	135.00	270.00	20.00	3T
9/16-12 UNC	124.00	248.00	25.00	4T
9/16-18 UNF	124.00	248.00	25.00	4T



PRICES SUBJECT TO CHANGE WITHOUT NOTICE 10/11/2018

- 10



# Pennoyer-Dodge Co. Standard Thread Rings Gages

American Gage Design / Short & Long Form Calibration Reports Available

## How To Order

1. State Quantity desired.
2. Nominal size and threads per inch and class of fit.  
Example: 1/4-28 UNF-2A
3. Go or Not Go or a set of gages.

**Call Toll Free  
1-800-736-4243**

4. Special marking for an additional charge.(\$15.00 min.)
5. Short Form c of c @ n/c. Long Form Calibration Reports add \$20.00 per member.
6. Calibration stickers available @ \$5.00 per sticker (advise calibration cycle).
7. CHROME: Add 50% for sizes #10 and up, per ring.
8. For "J" series (MIL-S-8879 and SAE-AS-71051), add \$70.00 per GO ring.

### CLASS X RIGHT HAND AGD THREAD RING GAGES

Nominal Size	Go or Not Go 2A or 3A	Go & Not Go Sets 2A or 3A	Ring Holder	Ring Holder Size
9/16-24 UNEF	146.00	292.00	25.00	4T
5/8-11 UNC	124.00	248.00	25.00	4T
5/8-18 UNF	125.00	250.00	25.00	4T
5/8-24 UNEF	153.00	306.00	25.00	4T
11/16-24 UNEF	153.00	306.00	25.00	4T
3/4-10 UNC	153.00	306.00	25.00	4T
3/4-16 UNF	153.00	306.00	25.00	4T
3/4-20 UNEF	175.00	350.00	25.00	4T
13/16-20 UNEF	175.00	350.00	25.00	4T
7/8-9 UNC	170.00	340.00	30.00	5T
7/8-14 UNF	170.00	340.00	30.00	5T
7/8-20 UNEF	190.00	380.00	30.00	5T
15/16-20 UNEF	190.00	380.00	30.00	5T
1-8 UNC	201.00	402.00	30.00	5T
1-12 UNF	201.00	402.00	30.00	5T
1-14 UNS	208.00	416.00	30.00	5T
1-20 UNEF	225.00	450.00	30.00	5T
1 1/16-18 UNEF	245.00	490.00	30.00	5T
1 1/8-7 UNC	240.00	480.00	30.00	5T
1 1/8-12 UNF	240.00	480.00	30.00	5T
1 1/8-18 UNEF	250.00	500.00	30.00	5T
1 3/16-18 UNEF	270.00	540.00	35.00	6T
1 1/4-7 UNC	265.00	530.00	35.00	6T
1 1/4-12 UNF	265.00	530.00	35.00	6T
1 1/4-18 UNEF	270.00	540.00	35.00	6T
1 5/16-18 UNEF	270.00	540.00	35.00	6T
1 3/8-6 UNC	265.00	530.00	35.00	6T
1 3/8-12 UNF	265.00	530.00	35.00	6T
1 3/8-18 UNEF	285.00	570.00	35.00	6T
1 7/16-18 UNEF	285.00	570.00	35.00	6T
1 1/2-6 UNC	282.00	564.00	35.00	6T
1 1/2-12 UNF	282.00	564.00	35.00	6T
1 1/2-18 UNEF	305.00	610.00	35.00	6T





# Pennoyer-Dodge Co. Truncated Setting Plug Gages

American Gage Design / Short & Long Form Calibration Reports Available

## How To Order

1. State Quantity desired.
2. Nominal size and threads per inch and class of fit.  
Example: 1/4-28 UNF-2A
3. Go or Not Go or a complete double end.
4. Handles: Either single end or double end. Handles ordered in colors other

**Call Toll Free  
1-800-736-4243**

- than Red or Green add \$20.00 per handle.
5. Special marking may be added for an additional charge. (\$15.00 min).
6. Short Form c of c @ n/c. Long Form Calibration Reports add \$20.00 per member.
7. Calibration stickers available @ \$5.00 per sticker (advise calibration cycle).
8. W-Tolerance P.D.: add 30%. Must purchase long form calibration reports.
9. "J" Series thread: Add \$8.00 per plug member.
10. Full Form set plugs available upon request.

### CLASS X P.D. RIGHT HAND TRUNCATED SETTING PLUG GAGES W-TOL ON LEAD & ANGLE

Nominal Size	Go or Not Go 2A or 3A Members	Complete Double End Gage w/Handle	Handle Only	Handle Size
# 0-80 UNF	109.00	233.00	15.00	# 000
# 1-64 UNC	109.00	233.00	15.00	# 000
# 1-72 UNF	109.00	233.00	15.00	# 000
# 2-56 UNC	109.00	233.00	15.00	# 000
# 2-64 UNF	109.00	233.00	15.00	# 000
# 3-48 UNC	103.00	221.00	15.00	# 000
# 3-56 UNF	103.00	221.00	15.00	# 000
# 4-40 UNC	93.00	201.00	15.00	# 00
# 4-48 UNF	93.00	201.00	15.00	# 00
# 5-40 UNC	85.00	185.00	15.00	# 00
# 5-44 UNF	85.00	185.00	15.00	# 00
# 6-32 UNC	85.00	185.00	15.00	# 00
# 6-40 UNF	85.00	185.00	15.00	# 00
# 8-32 UNC	85.00	185.00	15.00	# 0
# 8-36 UNF	85.00	185.00	15.00	# 0
# 10-24 UNC	85.00	185.00	15.00	# 0
# 10-32 UNF	85.00	185.00	15.00	# 0
# 12-24 UNC	90.00	195.00	15.00	# 0
# 12-28 UNF	90.00	195.00	15.00	# 0
# 12-32 UNEF	109.00	233.00	15.00	# 0
1/4-20 UNC	79.00	173.00	15.00	# 1
1/4-28 UNF	79.00	173.00	15.00	# 1
1/4-32 UNEF	110.00	235.00	15.00	# 1
5/16-18 UNC	79.00	173.00	15.00	# 1
5/16-24 UNF	79.00	173.00	15.00	# 1
5/16-32 UNEF	110.00	235.00	15.00	# 1
3/8-16 UNC	82.00	179.00	15.00	# 2
3/8-24 UNF	82.00	179.00	15.00	# 2
3/8-32 UNEF	125.00	265.00	15.00	# 2
7/16-14 UNC	85.00	185.00	15.00	# 2



PRICES SUBJECT TO CHANGE WITHOUT NOTICE 10/11/2018

- 12



# Pennoyer-Dodge Co.

## Truncated Setting Plug Gages

American Gage Design / Short & Long Form Calibration Reports Available

### How To Order

1. State Quantity desired.
2. Nominal size and threads per inch and class of fit.  
Example: 1/4-28 UNF-2A
3. Go or Not Go or a complete double end.
4. Handles: Either single end or double end. Handles ordered in colors other

**Call Toll Free**  
**1-800-736-4243**

- than Red or Green add \$20.00 per handle.
5. Special marking may be added for an additional charge. (\$15.00 min).
6. Short Form c of c @ n/c. Long Form Calibration Reports add \$20.00 per member.
7. Calibration stickers available @ \$5.00 per sticker (advise calibration cycle).
8. W-Tolerance P.D.: add 30%. Must purchase long form calibration reports.
9. "J" Series thread: Add \$8.00 per plug member.
10. Full Form set plugs available upon request.

CLASS X P.D. RIGHT HAND TRUNCATED SETTING  
PLUG GAGES W-TOL ON LEAD & ANGLE

Nominal Size	Go or Not Go 2A or 3A Members	Complete Double End Gage w/Handle	Handle Only	Handle Size
7/16-20 UNF	85.00	185.00	15.00	# 2
7/16-28 UNEF	125.00	265.00	15.00	# 2
1/2-13 UNC	89.00	193.00	15.00	# 2
1/2-20 UNF	89.00	193.00	15.00	# 2
1/2-28 UNEF	135.00	285.00	15.00	# 2
9/16-12 UNC	98.00	211.00	15.00	# 3
9/16-18 UNF	98.00	211.00	15.00	# 3
9/16-24 UNEF	145.00	305.00	15.00	# 3
5/8-11 UNC	104.00	223.00	15.00	# 3
5/8-18 UNF	104.00	223.00	15.00	# 3
5/8-24 UNEF	145.00	305.00	15.00	# 3
11/16-24 UNEF	155.00	325.00	15.00	# 3
3/4-10 UNC	120.00	255.00	15.00	# 3
3/4-16 UNF	120.00	255.00	15.00	# 3
3/4-20 UNEF	155.00	325.00	15.00	# 3
13/16-20 UNEF	158.00	331.00	15.00	# 3
7/8-9 UNC	143.00	301.00	15.00	# 4
7/8-14 UNF	143.00	301.00	15.00	# 4
7/8-20 UNEF	165.00	345.00	15.00	# 4
15/16-20 UNEF	165.00	345.00	15.00	# 4
1-8 UNC	159.00	333.00	15.00	# 4
1-12 UNF	159.00	333.00	15.00	# 4
1-14 UNS	159.00	333.00	15.00	# 4
1-20 UNEF	176.00	367.00	15.00	# 4
1 1/16-18 UNEF	176.00	367.00	15.00	# 4
1 1/8-7 UNC	176.00	367.00	15.00	# 4
1 1/8-12 UNF	176.00	367.00	15.00	# 4
1 1/8-18 UNEF	189.00	393.00	15.00	# 4
1 3/16-18 UNEF	192.00	399.00	15.00	# 5
1 1/4-7 UNC	195.00	405.00	15.00	# 5



PRICES SUBJECT TO CHANGE WITHOUT NOTICE 10/11/2018

- 13



# Pennoyer-Dodge Co. Truncated Setting Plug Gages

American Gage Design / Short & Long Form Calibration Reports Available

## How To Order

1. State Quantity desired.
2. Nominal size and threads per inch and class of fit.  
Example: 1/4-28 UNF-2A
3. Go or Not Go or a complete double end.
4. Handles: Either single end or double end. Handles ordered in colors other

**Call Toll Free  
1-800-736-4243**

- than Red or Green add \$20.00 per handle.
5. Special marking may be added for an additional charge. (\$15.00 min).
6. Short Form c of c @ n/c. Long Form Calibration Reports add \$20.00 per member.
7. Calibration stickers available @ \$5.00 per sticker (advise calibration cycle).
8. W-Tolerance P.D.: add 30%. Must purchase long form calibration reports.
9. "J" Series thread: Add \$8.00 per plug member.
10. Full Form set plugs available upon request.

### CLASS X P.D. RIGHT HAND TRUNCATED SETTING PLUG GAGES W-TOL ON LEAD & ANGLE

Nominal Size	Go or Not Go 2A or 3A Members	Complete Double End Gage w/Handle	Handle Only	Handle Size
1 1/4-12 UNF	195.00	405.00	15.00	# 5
1 1/4-18 UNEF	215.00	445.00	15.00	# 5
1 5/16-18 UNEF	215.00	445.00	15.00	# 5
1 3/8-6 UNC	215.00	445.00	15.00	# 5
1 3/8-12 UNF	215.00	445.00	15.00	# 5
1 3/8-18 UNEF	235.00	485.00	15.00	# 5
1 7/16-18 UNEF	235.00	485.00	15.00	# 5
1 1/2-6 UNC	240.00	495.00	15.00	# 5
1 1/2-12 UNF	240.00	495.00	15.00	# 5
1 1/2-18 UNEF	240.00	495.00	15.00	# 5





# Pennoyer-Dodge Co.

## \*Progressive Setting Plug Gages

American Gage Design / Short & Long Form Calibration Reports Available

### How To Order

1. State Quantity desired.
2. Nominal size and threads per inch and class of fit.  
Example: 1/4-28 UNF-2A Progressive
3. Go or Not Go or a complete double end.
4. Handles: Either single end or double end. Handles ordered in colors other than Red or Green add \$20.00 per handle.

**Call Toll Free  
1-800-736-4243**

5. Special marking may be added for an additional charge. (\$15.00 min)
6. Short Form c of c @ n/c. Long Form certifications add \$40.00 per member.
7. Calibration stickers available @ \$5.00 per sticker (advise calibration cycle).
8. "J" series thread add \$8.00 per plug member.

CLASS X P.D. RIGHT HAND PROGRESSIVE SETTING  
PLUG GAGES W-TOL ON LEAD & ANGLE

Nominal Size	Go or Not Go 2A or 3A Members	Complete Double End Gage w/Handle	Handle Only	Handle Size
# 0-80 UNF	134.00	283.00	15.00	# 000
# 1-64 UNC	134.00	283.00	15.00	# 000
# 1-72 UNF	134.00	283.00	15.00	# 000
# 2-56 UNC	134.00	283.00	15.00	# 000
# 2-64 UNF	134.00	283.00	15.00	# 000
# 3-48 UNC	123.00	261.00	15.00	# 000
# 3-56 UNF	123.00	261.00	15.00	# 000
# 4-40 UNC	123.00	261.00	15.00	# 00
# 4-48 UNF	123.00	261.00	15.00	# 00
# 5-40 UNC	112.00	239.00	15.00	# 00
# 5-44 UNF	112.00	239.00	15.00	# 00
# 6-32 UNC	112.00	239.00	15.00	# 00
# 6-40 UNF	112.00	239.00	15.00	# 00
# 8-32 UNC	112.00	239.00	15.00	# 0
# 8-36 UNF	112.00	239.00	15.00	# 0
# 10-24 UNC	112.00	239.00	15.00	# 0
# 10-32 UNF	112.00	239.00	15.00	# 0
# 12-24 UNC	112.00	239.00	15.00	# 0
# 12-28 UNF	112.00	239.00	15.00	# 0
# 12-32 UNEF	140.00	295.00	15.00	# 0
1/4-20 UNC	94.00	203.00	15.00	# 1
1/4-28 UNF	94.00	203.00	15.00	# 1
1/4-32 UNEF	127.00	269.00	15.00	# 1
5/16-18 UNC	94.00	203.00	15.00	# 1
5/16-24 UNF	94.00	203.00	15.00	# 1
5/16-32 UNEF	139.00	293.00	15.00	# 1
3/8-16 UNC	100.00	215.00	15.00	# 2
3/8-24 UNF	100.00	215.00	15.00	# 2
3/8-32 UNEF	152.00	319.00	15.00	# 2
7/16-14 UNC	100.00	215.00	15.00	# 2
7/16-20 UNF	100.00	215.00	15.00	# 2
7/16-28 UNEF	152.00	319.00	15.00	# 2
1/2-13 UNC	109.00	233.00	15.00	# 2
1/2-20 UNF	109.00	233.00	15.00	# 2
1/2-28 UNEF	158.00	331.00	15.00	# 2



\* Progressive master setting plugs differ from conventional truncated setting plugs in that the plug member contains two distinct P.D. limit areas. The limits are based on the Min. and Max. P.D. limits for the ring gage it will be used to inspect. The front portion contains the minimum P.D. limit with a full form major diameter, while the back portion contains the maximum P.D. limit with a truncated major diameter.

PRICES SUBJECT TO CHANGE WITHOUT NOTICE 10/11/2018

- 15



# Pennoyer-Dodge Co.

## \*Progressive Setting Plug Gages

American Gage Design / Short & Long Form Calibration Reports Available

### How To Order

1. State Quantity desired.
2. Nominal size and threads per inch and class of fit.  
Example: 1/4-28 UNF-2A Progressive
3. Go or Not Go or a complete double end.
4. Handles: Either single end or double end. Handles ordered in colors other than Red or Green add \$20.00 per handle.

**Call Toll Free**  
**1-800-736-4243**

5. Special marking may be added for an additional charge. (\$15.00 min)
6. Short Form c of c @ n/c. Long Form certifications add \$40.00 per member.
7. Calibration stickers available @ \$5.00 per sticker (advise calibration cycle).
8. "J" series thread add \$8.00 per plug member.

CLASS X P.D. RIGHT HAND PROGRESSIVE SETTING  
PLUG GAGES W-TOL ON LEAD & ANGLE

Nominal Size	Go or Not Go 2A or 3A Members	Complete Double End Gage w/Handle	Handle Only	Handle Size
9/16-12 UNC	121.00	257.00	15.00	# 3
9/16-18 UNF	119.00	253.00	15.00	# 3
9/16-24 UNEF	160.00	335.00	15.00	# 3
5/8-11 UNC	126.00	267.00	15.00	# 3
5/8-18 UNF	119.00	253.00	15.00	# 3
5/8-24 UNEF	163.00	341.00	15.00	# 3
11/16-24 UNEF	165.00	345.00	15.00	# 3
3/4-10 UNC	141.00	297.00	15.00	# 3
3/4-16 UNF	137.00	289.00	15.00	# 3
3/4-20 UNEF	167.00	349.00	15.00	# 3
13/16-20 UNEF	187.00	389.00	15.00	# 3
7/8-9 UNC	151.00	317.00	15.00	# 4
7/8-14 UNF	143.00	301.00	15.00	# 4
7/8-20 UNEF	193.00	401.00	15.00	# 4
15/16-20 UNEF	200.00	415.00	15.00	# 4
1-8 UNC	187.00	389.00	15.00	# 4
1-12 UNF	178.00	371.00	15.00	# 4
1-14 UNS	178.00	371.00	15.00	# 4
1-20 UNEF	211.00	437.00	15.00	# 4
1 1/16-18 UNEF	221.00	457.00	15.00	# 4
1 1/8-7 UNC	213.00	441.00	15.00	# 4
1 1/8-12 UNF	201.00	417.00	15.00	# 4
1 1/8-18 UNEF	221.00	457.00	15.00	# 4
1 3/16-18 UNEF	234.00	483.00	15.00	# 5
1 1/4-7 UNC	234.00	483.00	15.00	# 5
1 1/4-12 UNF	225.00	465.00	15.00	# 5
1 1/4-18 UNEF	234.00	483.00	15.00	# 5
1 5/16-18 UNEF	254.00	523.00	15.00	# 5
1 3/8-6 UNC	269.00	553.00	15.00	# 5
1 3/8-12 UNF	251.00	517.00	15.00	# 5
1 3/8-18 UNEF	258.00	531.00	15.00	# 5
1 7/16-18 UNEF	279.00	573.00	15.00	# 5
1 1/2-6 UNC	256.00	527.00	15.00	# 5
1 1/2-12 UNF	256.00	527.00	15.00	# 5
1 1/2-18 UNEF	280.00	575.00	15.00	# 5



\* Progressive master setting plugs differ from conventional truncated setting plugs in that the plug member contains two distinct P.D. limit areas. The limits are based on the Min. and Max. P.D. limits for the ring gage it will be used to inspect. The front portion contains the minimum P.D. limit with a full form major diameter, while the back portion contains the maximum P.D. limit with a truncated major diameter.

PRICES SUBJECT TO CHANGE WITHOUT NOTICE 10/11/2018

- 16

**PENNOYER-DODGE CO.**

**1-800-736-4243**

818-547-2100

Fax 1-818-240-5719





# Pennoyer-Dodge Co. Metric Thread Plug Gages

American Gage Design / Short & Long Form Calibration Reports Available

## How To Order

1. State Quantity desired.
2. Nominal size and threads per inch and class of fit.  
Example: 10.00 x 1.25-6H
3. Go or Not Go or a complete double end.
4. Handles: Either single end or double end. Handles ordered in colors other

**Call Toll Free  
1-800-736-4243**

- than Red or Green add \$20.00 per handle.
5. Special marking may be added for an additional charge. (\$15.00 min).
  6. Short Form c of c @ n/c. Long Form Calibration Reports add \$20.00 per member.
  7. Calibration stickers available @ \$5.00 per sticker (advise calibration cycle).
  8. CHROME: Add 50% to each member.
  9. For "MJ Series", Add \$8.00 per plug member.

### CLASS X RIGHT HAND METRIC THREAD PLUG GAGES

Nominal Size	Go or Not Go 6H Members	Complete Double End Gage w/Handle	Handle Only	Handle Size
M1.6 x 0.35	59.00	133.00	15.00	# 000
M2.0 x 0.40	57.00	129.00	15.00	# 000
M2.5 x 0.45	57.00	129.00	15.00	# 000
M3.0 x 0.50	57.00	129.00	15.00	# 00
M3.5 x 0.60	48.00	111.00	15.00	# 00
M4.0 x 0.70	48.00	111.00	15.00	# 0
M5.0 x 0.80	48.00	111.00	15.00	# 0
M6.0 x 1.00	41.00	97.00	15.00	# 0
M8.0 x 1.25	41.00	97.00	15.00	# 1
M10 x 1.00	44.00	103.00	15.00	# 2
M10 x 1.25	44.00	103.00	15.00	# 2
M10 x 1.50	44.00	103.00	15.00	# 2
M12 x 1.25	45.00	105.00	15.00	# 2
M12 x 1.50	45.00	105.00	15.00	# 2
M12 x 1.75	45.00	105.00	15.00	# 2
M14 x 1.50	51.00	117.00	15.00	# 3
M14 x 2.00	51.00	117.00	15.00	# 3
M16 x 1.50	52.00	119.00	15.00	# 3
M16 x 2.00	52.00	119.00	15.00	# 3
M18 x 1.50	57.00	129.00	15.00	# 3
M18 x 2.50	57.00	129.00	15.00	# 3
M20 x 1.00	69.00	153.00	15.00	# 3
M20 x 1.50	64.00	143.00	15.00	# 3
M20 x 2.50	64.00	143.00	15.00	# 3
M22 x 1.50	64.00	143.00	15.00	# 4





# Penroyer-Dodge Co. Metric Reversible Plug Gages

American Gage Design / Short & Long Form Calibration Reports Available

## How To Order

1. State Quantity desired.
2. Nominal metric size and metric threads per inch and class of fit.  
Example: 10.00 x 1.25-6H
3. Go or Not Go or a complete double end.
4. Handles: Either single end or double end. Handles ordered in colors other than Red or Green collets and other than plain handles, call for current pricing.

**Call Toll Free  
1-800-736-4243**

5. Special marking may be added for an additional charge. (\$15.00 min).
6. Short Form c of c @ n/c. Long Form Calibration Reports add \$20.00 per member.
7. Calibration stickers available @ \$5.00 per sticker (advise calibration cycle).
8. CHROME: Add 50% to each member.

CLASS X RIGHT HAND  
METRIC REVERSIBLE THREAD PLUG GAGES

Nominal Size	Go or Not Go 6H	Complete Double End Gage	Handle Only	Handle Size
M1.6 x 0.35	86.00	189.00	17.00	# 1W
M2.0 x 0.40	86.00	189.00	17.00	# 2W
M2.5 x 0.45	86.00	189.00	17.00	# 2W
M3.0 x 0.50	71.00	159.00	17.00	# 2W
M3.5 x 0.60	66.00	149.00	17.00	# 2W
M4.0 x 0.70	62.00	141.00	17.00	# 2W
M5.0 x 0.80	62.00	141.00	17.00	# 3W
M6.0 x 1.00	60.00	137.00	17.00	# 3W
M8.0 x 1.25	63.00	146.00	20.00	# 4W
M10 x 1.00	67.00	154.00	20.00	# 5W
M10 x 1.25	63.00	146.00	20.00	# 5W
M10 x 1.50	63.00	146.00	20.00	# 5W
M12 x 1.25	64.00	148.00	20.00	# 5W
M12 x 1.50	64.00	148.00	20.00	# 5W
M12 x 1.75	64.00	148.00	20.00	# 5W

CYLINDRICAL REVERSIBLE GAGES





# Pennoyer-Dodge Co. Metric Thread Ring Gages

American Gage Design / Short & Long Form Calibration Reports Available

## How To Order

1. State Quantity desired.
2. Nominal metric size and metric threads per inch and class of fit.  
Example: 10.00 x 1.25-6g
3. Go or Not Go or a complete set of rings.

**Call Toll Free  
1-800-736-4243**

4. Special marking may be added for an additional charge(\$15.00 min).
5. Short Form c of c @ n/c. Long Form Calibration Reports add \$20.00 per member.
6. Calibration stickers available @ \$5.00 per sticker (advise calibration cycle).
7. CHROME: Add 50% for size 5.0mm and up, per ring.
8. For "MJ Series", add \$70.00 per GO ring.

CLASS X RIGHT HAND  
METRIC THREAD RING GAGES

Nominal Size	Go or Not Go 6g Members	Go and Not Go 6g Pair of Rings	Ring Holder	Ring Holder Size
M1.6 x 0.35	170.00	340.00	20.00	# 1T
M2.0 x 0.40	150.00	300.00	20.00	# 1T
M2.5 x 0.45	150.00	300.00	20.00	# 1T
M3.0 x 0.50	130.00	260.00	20.00	# 1T
M3.5 x 0.60	130.00	260.00	20.00	# 1T
M4.0 x 0.70	122.00	244.00	20.00	# 1T
M5.0 x 0.80	122.00	244.00	20.00	# 1T
M6.0 x 1.00	115.00	230.00	20.00	# 1T
M8.0 x 1.25	115.00	230.00	20.00	# 2T
M10 x 1.00	122.00	244.00	20.00	# 3T
M10 x 1.25	120.00	240.00	20.00	# 3T
M10 x 1.50	120.00	240.00	20.00	# 3T
M12 x 1.25	120.00	240.00	20.00	# 3T
M12 x 1.50	125.00	250.00	20.00	# 3T
M12 x 1.75	130.00	260.00	20.00	# 3T
M14 x 1.50	130.00	260.00	25.00	# 4T
M14 x 2.00	140.00	280.00	25.00	# 4T
M16 x 1.50	140.00	280.00	25.00	# 4T
M16 x 2.00	145.00	290.00	25.00	# 4T
M18 x 1.50	185.00	370.00	25.00	# 4T
M18 x 2.50	190.00	380.00	25.00	# 4T
M20 x 1.00	235.00	470.00	25.00	# 4T
M20 x 1.50	230.00	460.00	25.00	# 4T
M20 x 2.50	235.00	470.00	25.00	# 4T
M22 x 1.50	240.00	480.00	30.00	# 5T





# Pennoyer-Dodge Co.

## Metric Truncated Setting Plug Gages

American Gage Design / Short & Long Form Calibration Reports Available

### How To Order

1. State Quantity desired.
2. Nominal metric size and metric threads per inch and class of fit.  
Example: 10.00 x 1.25-6g
3. Go or Not Go or a complete double end.
4. Handles: Either single end or double end. Handles ordered in colors other

**Call Toll Free**  
**1-800-736-4243**

5. than Red or Green add \$20.00 per handle.
6. Special marking may be added for an additional charge. (\$15.00 min).
7. Short Form c of c @ n/c. Long Form Calibration Reports add \$20.00 per member.
8. Calibration stickers available @ \$5.00 per sticker (advise calibration cycle).
9. W-tolerance P.D.: add 30%. Must purchase long form calibration report.
10. Full Form set plugs available upon request.
11. For "MJ Series", add \$8.00

CLASS X RIGHT HAND  
METRIC SETTING PLUG GAGES  
W-TOL ON LEAD & ANGLE

Nominal Size	Go or Not Go 6g Members	Complete Double End Gage w/Handle	Handle Only	Handle Size
M1.6 x 0.35	120.00	255.00	15.00	# 000
M2.0 x 0.40	114.00	243.00	15.00	# 000
M2.5 x 0.45	114.00	243.00	15.00	# 000
M3.0 x 0.50	110.00	235.00	15.00	# 00
M3.5 x 0.60	110.00	235.00	15.00	# 00
M4.0 x 0.70	106.00	227.00	15.00	# 0
M5.0 x 0.80	106.00	227.00	15.00	# 0
M6.0 x 1.00	95.00	205.00	15.00	# 0
M8.0 x 1.25	95.00	205.00	15.00	# 1
M10 x 1.00	96.00	207.00	15.00	# 2
M10 x 1.25	105.00	225.00	15.00	# 2
M10 x 1.50	105.00	225.00	15.00	# 2
M12 x 1.25	105.00	225.00	15.00	# 2
M12 x 1.50	105.00	225.00	15.00	# 2
M12 x 1.75	105.00	225.00	15.00	# 2
M14 x 1.50	120.00	255.00	15.00	# 3
M14 x 2.00	120.00	255.00	15.00	# 3
M16 x 1.50	120.00	255.00	15.00	# 3
M16 x 2.00	120.00	255.00	15.00	# 3
M18 x 1.50	130.00	275.00	15.00	# 3
M18 x 2.50	135.00	285.00	15.00	# 3
M20 x 1.00	150.00	315.00	15.00	# 3
M20 x 1.50	135.00	285.00	15.00	# 3
M20 x 2.50	135.00	285.00	15.00	# 3
M22 x 1.50	170.00	355.00	15.00	# 4





# Penroyer-Dodge Co.

## NPTF Taper Pipe Ring & Plug Gages

American Gage Design / Short & Long Form Calibration Reports Available

### How To Order

1. State Quantity desired.
2. Nominal size and L-1, L-2, or plain taper for ring gages and L-1, L-3, or plain taper for plug gages.  
Example: 1/16-27 NPTF L-2 RING
3. Handles: Either single end or double end. Handles ordered in colors other

**Call Toll Free**  
**1-800-736-4243**

- than Red or Green add \$20.00 each per handle.
4. Special marking for an additional charge, (\$15.00 min.)
5. NPTF plugs come with one basic step. If MN and /or MX steps desired, add \$35.00 per each additional step 1/16-27 to 1 1/2. Above 1 1/2, \$50.00.
6. Short Form c of c @ n/c. Long Form Calibration Reports add \$20.00 per member.
7. Calibration stickers available @ \$5.00 per sticker (advise calibration cycle).

### NPTF TAPER PIPE THREAD GAGES

Nominal Size	L-1 Ring Gage	L-2 Ring Gage	Plain Taper Ring Gage	L-1 Plug Gage	L-3 Plug Gage	Plain Taper Plug Gage	Handle Only	Handle Size
1/16-27	275.00	321.00	315.00	115.00	133.00	190.00	15.00	# 1
1/8-27	245.00	321.00	315.00	90.00	100.00	185.00	15.00	# 2
1/4-18	240.00	330.00	315.00	90.00	105.00	188.00	15.00	# 3
3/8-18	250.00	330.00	315.00	107.00	120.00	195.00	15.00	# 3
1/2-14	265.00	345.00	315.00	120.00	135.00	198.00	15.00	# 4
3/4-14	290.00	367.00	350.00	135.00	150.00	210.00	15.00	# 4
1" - 11.5	315.00	409.00	391.00	150.00	163.00	230.00	15.00	# 5
1 1/4 - 11.5	373.00	460.00	440.00	165.00	177.00	242.00	15.00	# 5
1 1/2 - 11.5	391.00	490.00	475.00	190.00	195.00	255.00	15.00	# 5
2" - 11.5	480.00	573.00	536.00	230.00	238.00	325.00	15.00	# 5
2 1/2 - 8	545.00	683.00	599.00	332.00	350.00	490.00	26.00	# 6
3"-8	597.00	806.00	753.00	385.00	410.00	550.00	26.00	# 6



### NOTE:

Master gages for NPT working gages are L-1 design.

Master gages for NPTF working gages are special design to encompass the L-1 and L-3 length for the master ring and the L-2 and L-3 length on the master plug. A set consists of (1) master plug and (1) master ring.

MIL-P-7105B and SAE-AS-71051 does not specify design on ANPT master. Penroyer-Dodge Co. designs these masters the same as the NPTF.



# Pennoyer-Dodge Co.

## ANPT Taper Pipe Ring & Plug Gages

American Gage Design / Short & Long Form Calibration Reports Available

### How To Order

1. State Quantity desired.
2. Nominal size and L-1, L-2, or plain taper for ring gages and L-1, L-3, or plain taper for plug gages.  
Example: 1/16-27 ANPT L-1 RING
3. Handles: Either single end or double end. Handles ordered in colors other

**Call Toll Free**  
**1-800-736-4243**

- than Red or Green add \$20.00 each per handle.
4. Special marking for an additional charge, (\$15.00 min.)
5. ANPT plugs come with one basic step. If MN and /or MX steps desired, add \$35.00 per each additional step 1/16-27 to 1 1/2, Above 1 1/2, \$50.00.
6. Short Form c of c @ n/c. Long Form Calibration Reports add \$20.00 per member.
7. Calibration stickers available @ \$5.00 per sticker (advise calibration cycle).

### ANPT TAPER PIPE THREAD GAGES

Nominal Size	L-1 Ring Gage	L-2 Ring Gage	Plain Taper Ring Gage	L-1 Plug Gage	L-3 Plug Gage	Plain Taper Plug Gage	Handle Only	Handle Size
1/16-27	275.00	326.00	316.00	145.00	175.00	190.00	15.00	# 1
1/8-27	245.00	326.00	316.00	140.00	155.00	185.00	15.00	# 2
1/4-18	240.00	330.00	316.00	140.00	155.00	188.00	15.00	# 3
3/8-18	250.00	330.00	316.00	142.00	155.00	195.00	15.00	# 3
1/2-14	265.00	345.00	316.00	145.00	165.00	198.00	15.00	# 4
3/4-14	290.00	387.00	351.00	156.00	175.00	205.00	15.00	# 4
1 - 11.5	315.00	419.00	391.00	170.00	190.00	230.00	15.00	# 5
1 1/4 - 11.5	373.00	468.00	440.00	202.00	205.00	242.00	15.00	# 5
1 1/2 - 11.5	391.00	492.00	475.00	208.00	225.00	248.00	15.00	# 5
2" - 11.5	480.00	586.00	536.00	243.00	261.00	325.00	15.00	# 5
2 1/2 - 8	545.00	697.00	599.00	375.00	363.00	490.00	26.00	# 6
3" - 8	669.00	823.00	753.00	444.00	444.00	550.00	26.00	# 6



### NOTE:

Master gages for NPT working gages are L-1 design.

Master gages for NPTF working gages are special design to encompass the L-1 and L-3 length for the master ring and the L-2 and L-3 length on the master plug. A set consists of (1) master plug and (1) master ring.

MIL-P-7105B and SAE-AS-71051 does not specify design on ANPT master. Pennoyer-Dodge Co. designs these masters the same as the NPTF.



# Pennoyer-Dodge Co.

## NPT Taper Pipe Ring & Plug Gages

American Gage Design / Short & Long Form Calibration Reports Available

### How To Order

1. State Quantity desired.
2. Nominal size and L-1 for ring gages or for plug gages.  
Example: 1/16-27 NPT L-1 RING or 1/16-27 NPT L-1 PLUG
3. Handles: Either single end or double end. Handles ordered in colors other than Red or Green add \$20.00 each per handle.

**Call Toll Free**  
**1-800-736-4243**

4. Special marking for an additional charge, (\$15.00 min.)
5. NPT plugs come with one basic step. If MN and/or MX steps desired, add \$35.00 per each additional step 1/16-27 to 1 1/2, Above 1 1/2, \$50.00.
6. Short Form c of c @ n/c. Long Form Calibration Reports add \$20.00 per member.
7. Calibration stickers available @ \$5.00 per sticker (advise calibration cycle).

### NPT TAPER PIPE THREAD GAGES

Nominal Size	L-1 Ring Gage	L-1 Plug Gage	Handle Only	Handle Size
1/16-27	275.00	93.00	15.00	# 1
1/8-27	225.00	73.00	15.00	# 2
1/4-18	235.00	75.00	15.00	# 3
3/8-18	245.00	80.00	15.00	# 3
1/2-14	265.00	88.00	15.00	# 4
3/4-14	285.00	101.00	15.00	# 4
1" - 11.5	310.00	115.00	15.00	# 5
1 1/4 - 11.5	373.00	128.00	15.00	# 5
1 1/2 - 11.5	391.00	142.00	15.00	# 5
2" - 11.5	480.00	173.00	15.00	# 5
2 1/2 - 8	545.00	210.00	26.00	# 6
3" - 8	597.00	240.00	26.00	# 6
3 1/2 - 8	821.00	375.00	30.00	# 7
4" - 8	1007.00	421.00	30.00	# 7
5" - 8	1176.00	580.00	30.00	# 7
6" - 8	1380.00	690.00	30.00	#7



### NOTE:

Master gages for NPT working gages are L-1 design.

Master gages for NPTF working gages are special design to encompass the L-1 and L-3 length for the master ring and the L-2 and L-3 length on the master plug. A set consists of (1) master plug and (1) master ring.

MIL-P-7105B and SAE-AS-71051 does not specify design on ANPT master. Pennoyer-Dodge Co. designs these masters the same as the NPTF.



# Pennoyer-Dodge Co. Cylindrical Taperlock Gages

American Gage Design / Short & Long Form Calibration Reports Available

## How To Order

1. State Quantity desired.
2. Nominal decimal size and tolerance class.  
Examples: .1500 class XX Go member, .1500 XX Go S.E.,  
.1500 - .1509 XX D.E. Gage.
3. Go or Not Go or a complete double end.
4. Handles, either single end or double end. Handles ordered in colors other than Red or Green add \$20.00 per handle.

5. Special marking may be added for an additional charge. (\$15.00 min).
6. Short Form calibration reports N/C. Long Form calibration reports add \$20.00 per member.
7. Calibration stickers available @ \$5.00 per sticker (advise calibration cycle).
8. CHROME: Add 50% to each member.
9. Must purchase long form calibration reports for all XX tolerance gages.

**Call Toll Free  
1-800-736-4243**

### CYLINDRICAL TAPERLOCK GAGES

Nominal Size		Go Class XX Members	Not Go Class XX Members	Go & Not Go D.E. Class XX W/Handle	Go Class X Members	Not Go Class X Members	Go & Not Go D.E. Class X W/Handle	Go Class Y & Z Members	Not Go Class Y & Z Members	Go & Not Go D.E. Class Y & Z W/Handle	Handle Only
Above	To & Incl										
0.059 (1.499mm)	0.105 (2.667mm)	75.00	74.00	141.00	60.00	58.00	131.00	60.00	58.00	131.00	15.00
0.105 (2.667mm)	0.150 (3.810mm)	67.00	66.00	135.00	57.00	55.00	125.00	57.00	55.00	125.00	15.00
0.150 (3.810mm)	0.230 (5.842mm)	67.00	66.00	135.00	57.00	55.00	125.00	57.00	55.00	125.00	15.00
0.230 (5.842mm)	0.510 (12.954mm)	67.00	66.00	137.00	58.00	56.00	127.00	58.00	56.00	127.00	15.00
0.510 (12.954mm)	0.825 (20.955mm)	74.00	73.00	146.00	63.00	60.00	136.00	63.00	60.00	136.00	15.00
0.825 (20.955mm)	1.135 (28.829mm)	77.00	75.00	153.00	65.00	63.00	141.00	65.00	63.00	141.00	15.00
1.135 (28.829mm)	1.510 (38.354mm)	79.00	78.00	157.00	67.00	64.00	145.00	67.00	64.00	145.00	15.00







# Pennoyer-Dodge Co. Cylindrical Reversible Gages

American Gage Design / Short & Long Form Calibration Reports Available

## How To Order

1. State Quantity desired.
2. Nominal decimal size and tolerance class and Go, Not Go or Master.  
Examples: .1500 class XX Go member, .1500 XX Go S.E.,  
.1500 - .1509 XX D.E. Gage.
3. Types: Go, Not Go or Master, single end or a complete double end.
4. Handles: Either single end or double end. Handles ordered in colors other than Red or Green collets and other than plain handles, call for current pricing.
5. Special marking may be added for an additional charge. (\$15.00 min).
6. Short Form c of c @ n/c. Long Form calibration report add \$20.00 per member.
7. Calibration stickers available @ \$5.00 per sticker (advise calibration cycle).

8. All pin style above 1.010, price upon application.
9. CHROME: Add 50% to each member. Sizes < .080, price upon application.
10. XXX gages price upon application, on sizes .125 and larger.
11. Use Z prices shown below for inch sizes in thousands and half thousands, and two decimal places metric sizes. For Z pin sizes other than this, use X & Y column pricing. Purchase of Long Form Calibration Reports required on all XX, X, and Y pins.
12. Extra length gages available, price on application.

**Call Toll Free  
1-800-736-4243**

### CYLINDRICAL REVERSIBLE GAGES

Nominal Size		Class XX Members	Class XX D.E.	Class X & Y Members	Class X & Y D.E.	Class Z Members	Class Z D.E.	Handle Only
Above	To & Incl							
.035 (0.889mm)	.075 (1.905mm)	88.00	193.00	59.00	135.00	49.00	115.00	17.00
.075 (1.905mm)	.100 (2.540mm)	88.00	193.00	59.00	135.00	49.00	115.00	17.00
.100 (2.540mm)	.180 (4.572mm)	79.00	175.00	52.00	121.00	42.00	101.00	17.00
.180 (4.572mm)	.510 (12.954mm)	79.00	178.00	52.00	124.00	42.00	104.00	20.00
.510 (12.954mm)	.760 (19.304mm)	88.00	201.00	59.00	143.00	42.00	109.00	25.00
.760 (19.304mm)	1.010 (25.654mm)	111.00	257.00	72.00	179.00	55.00	145.00	35.00



Handle Size	Above	To & Including
1w	.030	.075
2w	.075	.180
3w	.180	.281
4w	.281	.406
5w	.406	.510
6w	.510	.635
7w	.635	.760
8w	.760	1.010



# Pennoyer-Dodge Co. Cylindrical Trilock Gages

Call Toll Free  
1-800-736-4243

American Gage Design / Short & Long Form Calibration Reports Available

## How To Order

1. State Quantity desired.
2. Nominal decimal size and tolerance class class and Go, Not Go or Master.  
Examples: .1500 class XX Go member, .1500 XX Go S.E.,  
.1500 - .1509 XX D.E. Gage.
3. Go or Not Go or a complete double end.
4. Handles: Either single end or double end. Handles ordered in colors other than Red or Green add \$20.00 per handle.

5. Special marking may be added for an additional charge. (\$15.00 min).
6. Short Form c of c @ n/c. Long Form Calibration Reports add \$20.00 per member.
7. Calibration stickers available @ \$5.00 per sticker (advise calibration cycle).
8. All pin style above .760 up to and including 1.500 price upon application.
9. All trilock style from .760 up to and including 1.500 price upon application.
10. CHROME: Add 50% to each member.
11. XXX gages quoted upon request.
12. Must purchase long form calibration reports for all XX tolerance gages.

### CYLINDRICAL TRILOCK GAGES

Nominal Size		Go Class XX Members	Not Go Class XX Members	Go & Not Go Class XX W/Handle	Go Class X Members	Not Go Class X Members	Go & Not Go Class X W/Handle	Go Class Y & Z Members	Not Go Class Y & Z Members	Go & Not Go Class Y & Z W/Handle	Handle Only
Above	To & Incl										
1.510 (38.354mm)	1.760 (44.704mm)	115.00	111.00	241.00	108.00	97.00	231.00	97.00	94.00	217.00	26.00
1.760 (44.704mm)	2.010 (51.054mm)	115.00	111.00	241.00	108.00	97.00	231.00	105.00	97.00	228.00	26.00
2.010 (51.054mm)	2.260 (57.404mm)	139.00	123.00	267.00	119.00	107.00	252.00	108.00	100.00	234.00	26.00
2.260 (57.404mm)	2.510 (63.754mm)	139.00	123.00	267.00	119.00	107.00	252.00	108.00	100.00	234.00	26.00
2.510 (63.754mm)	2.760 (70.104mm)	162.00	139.00	333.00	140.00	112.00	312.00	119.00	110.00	289.00	30.00
2.760 (70.104mm)	3.010 (76.454mm)	162.00	139.00	333.00	140.00	112.00	312.00	119.00	110.00	289.00	30.00
3.010 (76.454mm)	3.260 (82.804mm)	236.00	186.00	445.00	199.00	175.00	418.00	175.00	162.00	397.00	30.00
3.260 (82.804mm)	3.510 (89.154mm)	236.00	186.00	445.00	199.00	175.00	418.00	175.00	162.00	397.00	30.00





# Pennoyer-Dodge Co. Cylindrical Progressive Gages

American Gage Design / Short & Long Form Calibration Reports Available

## How To Order

1. State Quantity desired.
2. Nominal decimal size and tolerance class and Go, Not Go or Master.  
Examples: .1500 class XX Go member, .1500 XX Go S.E.,  
.1500 - .1509 XX D.E. Gage.
3. Handles: Either single end or double end. Handles ordered in colors other than Red or Green add \$20.00 per handle.
4. Special marking may be added for an additional charge. (\$15.00 min).
5. Short Form c of c @ n/c. Long Form Calibration Reports add \$40.00 per member.
6. Calibration stickers available @ \$5.00 per sticker (advise calibration cycle).
7. CHROME: Add 50% to each member.
8. Must purchase long form calibration reports for all XX tolerance gages.

**Call Toll Free  
1-800-736-4243**

CYLINDRICAL PROGRESSIVE GAGES

Nominal Size		Class XX Members	Class X Members	Class Y & Z Members	Handle Only
Above	To & Incl				
.059 (1.499mm)	.105 (2.667mm)	130.00	129.00	125.00	15.00
.105 (2.667mm)	.150 (3.810mm)	112.00	102.00	95.00	15.00
.150 (3.810mm)	.185 (4.699mm)	110.00	100.00	91.00	15.00
.185 (4.699mm)	.230 (5.842mm)	112.00	100.00	92.00	15.00
.230 (5.842mm)	.365 (9.271mm)	112.00	100.00	92.00	15.00
.365 (9.271mm)	.510 (12.954mm)	114.00	100.00	94.00	15.00
.510 (12.954mm)	.635 (16.129mm)	122.00	109.00	100.00	15.00
.635 (16.129mm)	.760 (19.304mm)	122.00	109.00	100.00	15.00
.760 (19.304mm)	.825 (20.955mm)	123.00	109.00	100.00	15.00
.825 (20.955mm)	1.135 (28.829mm)	136.00	116.00	112.00	15.00
1.135 (28.829mm)	1.510 (38.354mm)	155.00	121.00	113.00	15.00





# Pennoyer-Dodge Co. Cylindrical Ring Gages

American Gage Design / Short & Long Form Calibration Reports Available

## How To Order

1. State Quantity desired.
2. Nominal decimal size and tolerance class.  
Example: .150 class XX
3. Go or Not Go or a Master ring.
4. Special marking may be added for an additional charge. (\$15.00 min).
5. Short Form Calibration Reports N/C. Long Form Calibration Reports add \$20.00 per ring.

6. Calibration stickers available @ \$5.00 per sticker (advise calibration cycle).
7. CHROME: Add 50% per ring for .125 and up..
8. XXX Master rings quoted upon request.
9. Must purchase long form calibration reports for all XX tolerance gages.

**Call Toll Free  
1-800-736-4243**

### CYLINDRICAL RING GAGES

Above	Nominal Size To & Incl	Class XX Members	Class X Members	Class Y & Z Members
.062 (1.575mm)	.070 (1.778mm)	195.00	160.00	157.00
.070 (1.778mm)	.090 (2.286mm)	179.00	148.00	145.00
.090 (2.286mm)	.150 (3.810mm)	179.00	148.00	145.00
.150 (3.810mm)	.230 (5.842mm)	135.00	123.00	115.00
.230 (5.842mm)	.365 (9.271mm)	117.00	108.00	103.00
.365 (9.271mm)	.510 (12.954mm)	118.00	109.00	102.00
.510 (12.954mm)	.825 (20.955mm)	123.00	114.00	107.00
.825 (20.955mm)	1.135 (28.829mm)	125.00	122.00	113.00
1.135 (28.829mm)	1.510 (38.354mm)	155.00	137.00	127.00
1.510 (38.354mm)	2.010 (51.054mm)	188.00	173.00	162.00
2.010 (51.054mm)	2.510 (63.754mm)	233.00	210.00	194.00
2.510 (63.754mm)	3.010 (76.454mm)	270.00	239.00	221.00
3.010 (76.454mm)	3.510 (89.154mm)	314.00	278.00	257.00
3.510 (89.154mm)	4.010 (101.854mm)	360.00	326.00	302.00
4.010 (101.854mm)	4.760 (120.904mm)	412.00	355.00	329.00
4.760 (120.904mm)	5.510 (139.954mm)	551.00	459.00	421.00



PRICES SUBJECT TO CHANGE WITHOUT NOTICE 10/11/2018

- 28



# Pennoyer-Dodge Co.

## Gage Re-Calibration Charges

The following "**Standard Published**" prices are for calibration of customer submitted thread plugs; thread rings; pipe plugs and rings; and cylindrical plug and rings **regardless of calibration results**. Expedited, safety related and Special Calibration charges are priced on application and will not be waived, regardless of the calibration results.

**Pennoyer-Dodge Co.** also manufacture's and/or calibrates many other types of gages. Please call/fax your inquiries.

Calibration of gages in accordance to ISO 10012-1, ANSI/NCSL Z540-1, Mil-Std-45662A. Minimum order is \$50.00

THREAD PLUGS (PER MEMBER)	STANDARDS	SET PLUGS	PIPE	SIX STEP
ANY SIZE 60 DEGREE & METRIC'S FROM # 0 THUR 3"	22.00	33.00	50.00	55.00
OVER 3" TO 6"	33.00	45.00	CALL	CALL
OVER 6" and High/Low	CALL FOR CURRENT PRICING	CALL FOR CURRENT PRICING	CALL FOR CURRENT PRICING	CALL FOR CURRENT PRICING

THREAD RINGS (PER RING)	STANDARDS	PIPE	SIX STEP
STANDARD UNC, UNF AND UNEF FROM # 0 TO 1 1/2"	33.00	55.00	60.00
STANDARDS ABOVE 1 1/2" TO 3" AND SPECIALS UP TO 3" (60 DEGREE)	55.00	70.00	75.00
OVER 3" (60 DEGREE)	CALL FOR CURRENT PRICING	CALL FOR CURRENT PRICING	CALL FOR CURRENT PRICING

CYLINDRICAL PLUGS	PER MEMBER
UP TO .020	CALL FOR CURRENT PRICING
Above .020 THRU 5.00	25.00
OVER 5.00	CALL FOR CURRENT PRICING
FOR XXX TOL. CALIBRATION	CALL FOR CURRENT PRICING

CYLINDRICAL RINGS	PER MEMBER
.059 THRU .125	55.00
Above .125 THRU 4.010	40.00
Above 4.010 THRU 6.010	50.00
OVER 6.010	CALL FOR CURRENT PRICING
FOR XXX TOL. CALIBRATION	CALL FOR CURRENT PRICING

PRICES SUBJECT TO CHANGE WITHOUT NOTICE 10/11/2018

- 29



Pennoyer-Dodge Co.

## Special Gage Listing

Special Precision Gages Now Manufactured by

**Pennoyer-Dodge Company**

### PLUG GAGES - THREAD

Standard 60° N.F., N.C.,  
UNC, UNF, UNJ, UNJF,  
NEF, UNEF  
Setting "X" and "W" tol.  
S.T.I. "X" and "W" tol.  
Acme 29° Stub & Trapezoidal  
Threads  
Buttress Threads  
Metric Threads  
Whitworth 55°  
Straight Pipe,  
NPSC, NPSF, NPSI, NPSM,  
NPSL  
Taper Pipe, NPT, NPTF,  
ANPT, BSP  
Taper Pipe, Setting  
British Pipe Threads  
Taper Threads  
Square Threads  
A N Port  
M S Threads  
Hose Fittings  
Position Gages

### RING GAGES- THREAD

Metric  
60° N.F., N.C., UNC, UNJ,  
UNJF, NEF & UNEF  
Acme  
Buttress  
Whitworth 55°  
Straight Pipe, NPSC, NPSF,  
NPSI, NPSM, NPSL  
Taper Pipe, NPT, NPTF, ANPT,  
BSP  
British Pipe  
Taper  
Square

### VARIABLE GAGING - INTER- NAL & EXTERNAL

Trirolls  
Internal Thread Comparator

### SNAP GAGES

Plain Adjustable  
Built-up  
Fixed Solid  
Special Indicating  
Roll Thread to Mil-Std-8879A and  
Mil-Std-7742A, Amendment No. 1  
Methods A and B.

### AIR GAGE TOOLING

Air Ring  
Air Probe  
Related Masters

### OIL FIELD GAGES

Sucker Rod  
Casing  
Tubing  
Line Pipe  
Rotary

### PLUG GAGES - PLAIN CYLINDRICAL

Flat, hex, & Square  
Progressive Type  
Plain Taper (Master) Brown &  
Sharpe, Luer Gages, etc.  
Morse or any Special Taper to  
Print.  
Plain Cylindrical, Taperlock, Re-  
versible, Trilock  
M S  
Master Disks Style 1,2 & 3  
Paddle Type  
Depth  
M S Flush  
Flush Pin  
Functional  
A N Port  
Thread Measuring Wires

### RING GAGES -

#### PLAIN CYLINDRICAL

Plain, Go, Not Go, Master Setting  
Taper  
Progressive

#### SPECIAL TOOLING

Hole Location Gages  
Drill Fixtures  
Milling Fixtures  
Mandrills  
Template Gages  
Spanner Gages  
Receiver Gages  
Fixture Gages  
Functional Gages  
Concentricity & Runout Gages  
Profile Gages  
Crimping Tool Gages  
Flush Pin Gages  
Paddle Gages  
Chamber Gages

#### SPECIAL SERVICES

Certification on all types of Gages  
listed, traceable to N.I.S.T.  
Lead Screws  
Thread Grinding to close toleranc-  
es.  
Jig Grinding  
Lap I.D. and O.D. Parts to close  
tolerances.  
Lapping of Plugs and Rings -  
Both Plain and Threads.



# Pennoyer-Dodge Co.

## Accurate Formula To Compute The Pitch And Major/Minor Diameters For Before Plate Thread Plugs And Thread Rings\*

If no plating tolerance is given, then it is assumed that the maximum plating thickness will be nominal or minimum thickness given plus 50%. (see ASME B1.1-2003, pg. 64, 7.4.2; pg. 65, 7.5.2) The diameters of the gaging for external threads will be smaller while the diameters of the gaging for internal threads will be larger, than standard.

### THREAD PLUGS

For the Go plug pitch diameter, **add** the **MAX.** amount of plate. For the Not Go pitch diameter, **add** the **MIN.** amount of plate. For the majors of work plugs, **increase** the major diameter on Go work plug by using half the **MAX.** amount of plate. On Not Go work plugs, **increase** the major diameter by using half the **MIN.** amount of plate.

#### Example

Based on .0002 to .0003 allowance per side (multiply by 4)

.0002 X 4 = .0008 **MIN.**

.0003 X 4 = .0012 **MAX.**

1/4-28 UNF 2B B/P

Basic GO P.D. .2268 + .0012 **MAX.** = .2280 Go P.D.

Basic NOT GO P.D. .2311 + .0008 **MIN.** = .2319 Not Go P.D.

Basic GO major .2500 + (.0012 / 2) = .2506 B/P Go major.

Basic NOT GO major .2466 + (.0008 / 2) = .2470 B/P Not Go major.

### THREAD RINGS

For the Go ring, **subtract** the **MAX.** amount of plate. For the Not Go ring, **subtract** the **MIN.** amount of plate. For the minors of thread rings, **decrease** the minor diameter on the Go thread ring by using half the **MAX.** amount of plate. On Not Go thread rings, **decrease** the minor diameter by using half the **MIN.** amount of plate.

#### Example

Based on .0002 to .0003 allowance per side (multiply by 4)

.0002 X 4 = .0008 **MIN.** .0003 X 4 = .0012 **MAX.**

1/4-28 UNF 2A B/P

Basic GO P.D. .2258 - .0012 **MAX.** = .2246 Go P.D.

Basic NOT GO P.D. .2225 - .0008 **MIN.** = .2217 Not Go P.D.

Basic GO minor .2103 - (.0012 / 2) = .2097 B/P Go minor.

Basic NOT GO minor .2148 - (.0008 / 2) = .2144 B/P Not Go minor.

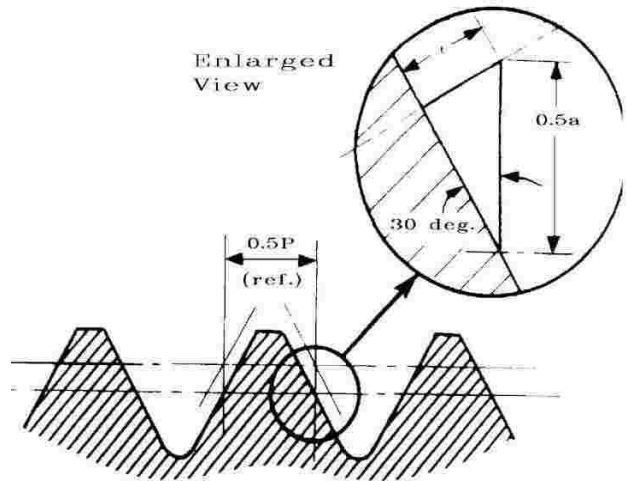

### RATIO OF PITCH DIAMETER CHANGE TO THICKNESS OF COATING (60° ONLY)

t = thickness of coating

a = pitch diameter change due to coating

0.25a = t and a = 4t or the pitch diameter of a 60° thread changes by four times the thickness of the coating

### BEFORE PLATING RATIOS FOR PITCH DIAMETER

60° thread = 4:1

29° Acme = 8:1

7°-45° Buttress = 4.3138:1

14° 30'-5° Buttress = 11.9311:1

10° Square thread = 23:1

**Anodic Coatings**—When calculating dimensions for pre-anodize gaging, a modification from the two above examples given, must be made.

For example, when calculating the increase in dimensions for the pre-anodize work plug gages, the value of thickness amount of the anodize applied, must be, for gage calculations purposes, reduced by one half, i.e., if the minimum and maximum applied anodize thickness dimensions were, .0004 to .0006 per surface, the values used in the calculations, would be only one half of the application, or .0002 to .0003 per surface. The results, in this example, would then be the same values, as the example shown above for the thread plugs. For thread rings, the same procedure would be utilized, in reverse. Reference Data: MIL-A-8625F, page 16.

\* In accordance with ANSI/ASME B1.1-2003

# PENNOYER-DODGE CO.

introduces

## "TWIST'ER GAGES"



MMC

RFC

LMC



SPC

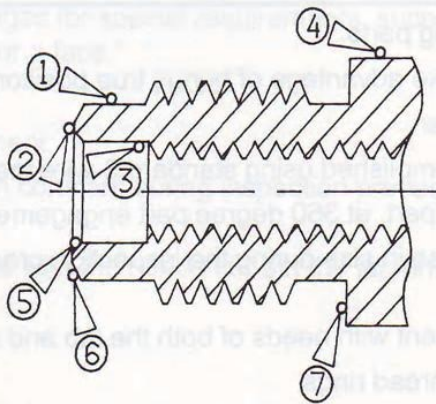

### Functional Location - P.D. Limit & Size

*"When you want it Right...and Right away"*

PRICES SUBJECT TO CHANGE WITHOUT NOTICE 10/11/2018 - 32





Pennoyer-Dodge Co.

## “ TWISTER OUT ”

### YOUR CHOICE FOR FUNCTIONAL THREADED AXIS LOCATION, REGARDLESS OF FEATURE SIZE

#### “TWISTER OUT” RING PRINCIPLE:

The “TWISTER OUT” ring with its P.D. (Functional Diameter) related ground O.D. and faces, works by two independent thread gage sections that, when twisted, grips the flanks of the product thread. This locks and locates the functional thread axis of the product thread. At this point a variety of inspection techniques are possible, such as true position, runout, and concentricity to the part functional P.D. (Functional Diameter) datum.

#### “TWISTER OUT” RING FEATURES:

- Reliable functional pitch diameter datum source for location of functional thread axis position.
- Accuracy to .0001
- No complicated moving parts.
- Easily adapted for SPC.
- Use of high quality tool steel (**Chrome also** available).
- Engineered and manufactured in the U.S.A.

#### “TWISTER OUT” RING ADVANTAGES:

- Allows part manufacturer to accurately determine runout, perpendicularity, true position, and
- concentricity of part parameters to the P.D. (Functional Diameter) RFS EXAMPLE: 

	Ø.005	P.D. (Functional Diameter)
---	-------	----------------------------
  - Inspects functional thread plug gages for special requirements, such as: “Pitch diameter of gages must run within .0002 to centers, or a face.”
  - Assures assemblability .
  - Checks 360 degree part engagement.
  - Major and minor diameters remain constant during inspection process as compared to alternate types of gaging.
  - Portability and accuracy consistent with the needs of both the lab and manufacturing environment

Prices available upon application

PRICES SUBJECT TO CHANGE WITHOUT NOTICE 10/11/2018

- 33



Pennoyer-Dodge Co.

## “ TWISTER IN”

### YOUR CHOICE FOR PRECISION THREAD LOCATION AND FUNCTIONAL SIZE

#### “TWISTER IN” PLUG PRINCIPLE:

The “TWISTER ” plug works by movable thread gage segments that engage one flank angle, while the thread body engages the opposite thread flank angle of the product thread. The resultant “flank grip” establishes the functional size and/or functional thread axis of the part, depending on how the twister plug is fabricated.

#### “TWISTER IN” PLUG FEATURES:

- Reliable functional pitch diameter datum source for functional size determination and/or functional thread axis location.
- Accuracy to .0001
- No complicated moving parts.
- Easily adapted for SPC.
- Consistent readings.
- Locks readings in place.
- Use of high quality tool steel (**Chrome also** available).
- Engineered and manufactured in the U.S.A.

#### “TWISTER IN” PLUG ADVANTAGES:

- Allows part manufacturer to take advantage of bonus true position part tolerancing 

$\oplus$	$\varnothing.005$	$\textcircled{M}$	P.D. (Functional Diameter)
----------	-------------------	-------------------	----------------------------
- **No need** for solid ring set master.
- Assures assemblability.
- Can measure functional size of part, at 360 degree part engagement.
- Major diameter does not increase in size during the inspection process , as compared to alternate types of gages.
- Portability and accuracy consistent with the needs of both the lab and manufacturing environment
- Calibrate adjustable and solid thread rings.

Prices available upon application

PRICES SUBJECT TO CHANGE WITHOUT NOTICE 10/11/2018

- 34

## STANDARD GAGING

**Penroyer-Dodge Company** has one of the largest selections of standard and **special gages** in stock. In many instances they are available for immediate delivery.

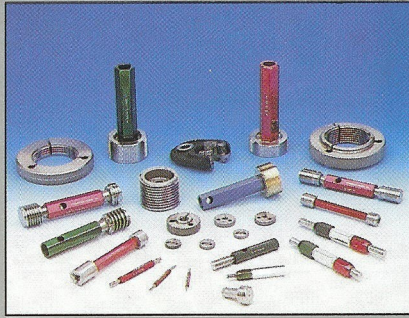

### CERTIFICATION OPTIONS

1. Short Form Certificate of Conformance - No Charge
2. Long Form Certifications with actual dimensions available at nominal charge.

All gages are hand lapped for longer wear.

All gages are certified in accordance to MIL-STD-45662A and are traceable to the N.I.S.T.

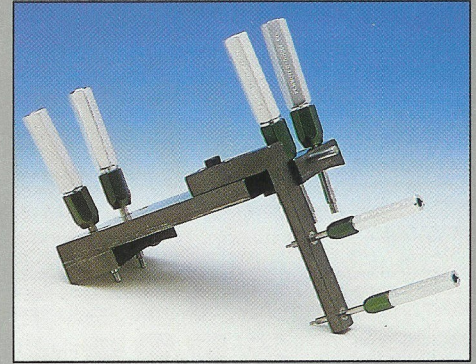
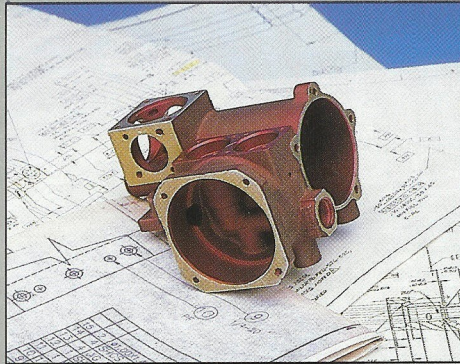

## CUSTOM ENGINEERING AND SPECIAL TOOLING

- **Fabrication** of custom gages to existing gage drawings.
- **Design and fab** capabilities from concept to completion per ANSI Y14.5.
- As a leader in the design and production of Functional Gages, we are familiar with the problems of the manufacturing industry. We invite you to request our services regardless of your R & D or engineering needs. We can design a new gage, or develop a less costly method to meet your present gaging needs.

## OTHER SERVICES



- Parts analysis and "troubleshooting".
- Contract Jig Grinding with open machine time available.
- Custom Lapping.
- Special Thread Grinding.

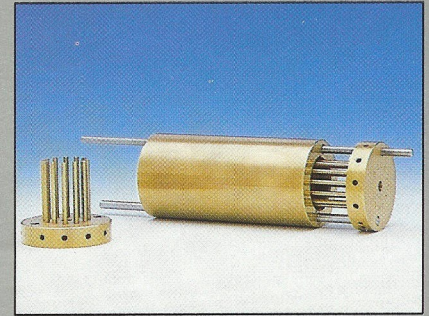

*"When you want it right ... and right away" - Call...*

**PENROYER-DODGE COMPANY, GLENDALE, CA.**

CALL TOLL FREE 1-800-PEN-GAGE FAX: (818) 240-5719 (213) 245-8971 (818) 240-1170

## INDUSTRIES SERVED

- AEROSPACE    • AIRCRAFT    • AUTOMOTIVE    • COMMERCIAL APPLICATION
- COMPUTER    • DEFENSE    • ELECTRONICS
- MEDICAL    • NUCLEAR    • OIL FIELD    • ORDINANCE

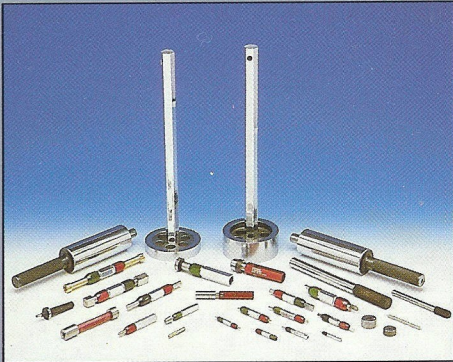

## PRODUCTS AND SERVICES AVAILABLE

THREAD PLUG GAGES  
 THREAD RING GAGES  
 THREAD SETTING PLUGS  
 REVERSIBLE THREAD GAGES  
 S.T.I. THREAD GAGES  
 OIL COUNTRY GAGES  
 TAPERED PIPE GAGES  
 METRIC GAGES  
 ACME GAGES  
 BUTTRESS GAGES  
 WHITWORTH GAGES  
 SQUARE THREADS  
 BRITISH PIPE GAGES  
 VARIABLE GAGING

CYLINDRICAL PLUG GAGES  
 CYLINDRICAL RING GAGES  
 PROGRESSIVE PLUG GAGES  
 PIN TYPE GAGES  
 MASTER DISKS  
 PROFILE GAGES  
 M.S. PLUG GAGES  
 A.N. PORT PLUG GAGES  
 HOSE FITTING GAGES  
 PADDLE GAGES  
 LEUR GAGES  
 AIR PLUGS AND PROBES  
 MANDRILS

FIXTURE GAGES  
 FLUSH PIN GAGES  
 CONCENTRICITY GAGES  
 TRUE POSITION GAGES  
 RADIUS GAGES  
 RECEIVER GAGES  
 TEMPLATE GAGES  
 CRIMPING TOOL GAGES  
 ROLL THREAD SNAP GAGES  
 (ALSO CONE & V)  
 CUSTOM LAPPING  
 LEAD SCREWS  
 SPECIAL THREAD GRINDING  
 CONTRACT JIG GRINDING

*"When you want it right ... and right away"*

**PENNOYER-DODGE COMPANY**  
 6634 SAN FERNANDO ROAD  
 GLENDALE, CALIFORNIA 91201



CALL

**Our New Number**

(818) 547-2100 • FAX (818) 240-5719  
 6650 SAN FERNANDO ROAD  
 GLENDALE, CA 91201-1017  
 TOLL FREE (800) 736-4243