

PENNOYER - DODGE
CO
PENNOYER - DODGE
CO
PRECISION GAGES
PENNOYER - DODGE
C O M P A N Y
PRECISION GAGES

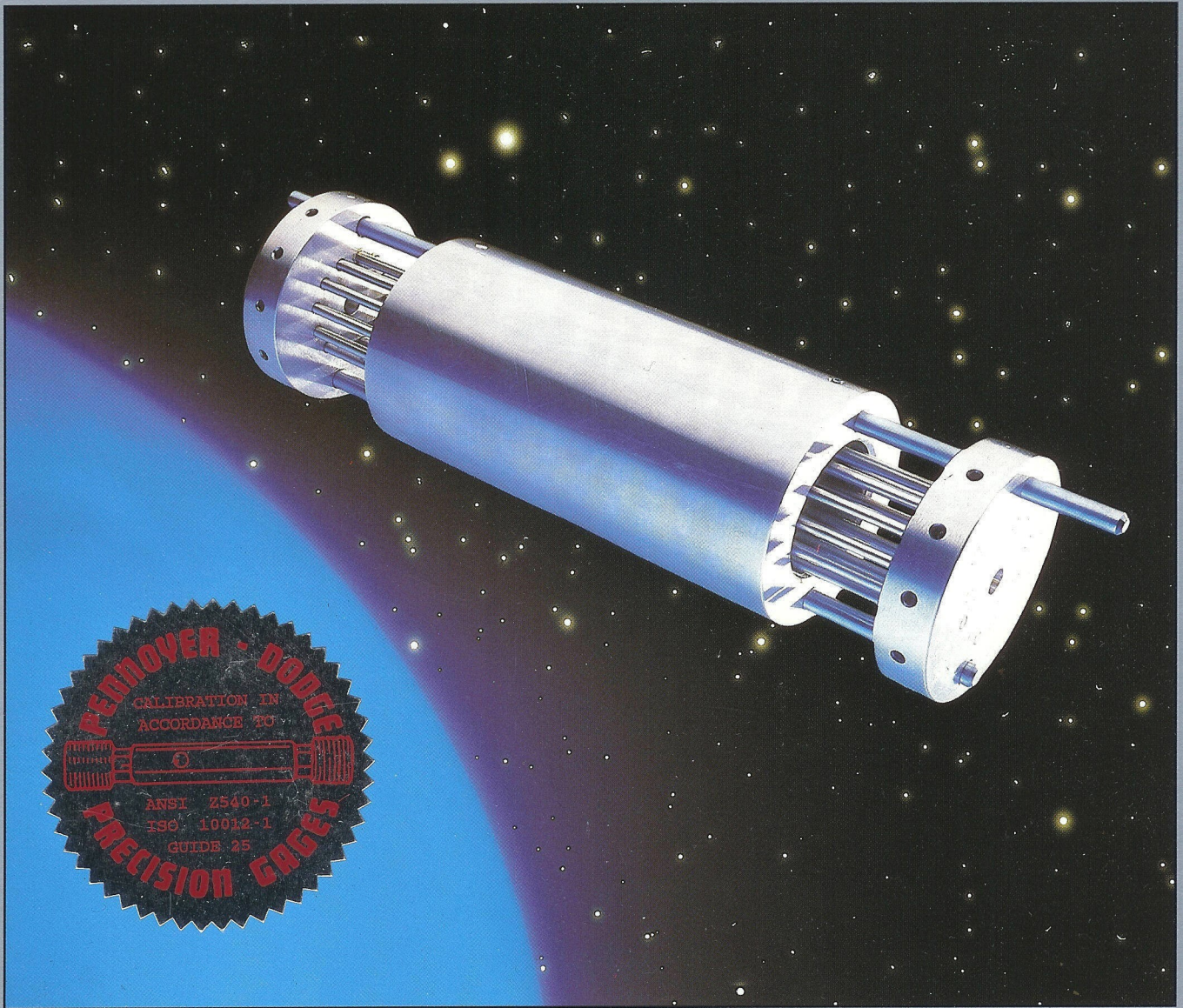

GAGING AND TOOLING SPECIALIST
SINCE 1948

QUALITY

SALES

SERVICE



MESSAGE FROM THE PRESIDENT



Dear Customer,

Welcome to **Penneyer-Dodge Company!** You are about to meet a family owned company that has been in the Precision Gage business since 1948. **Penneyer-Dodge Company** is a leader in the manufacturing of all types of precision thread and cylindrical gages, as well as the design and manufacturing of special fixture gaging.

The basic philosophy of **Penneyer-Dodge Company** has always been that our customers deserve our best effort. We know that quality and confidence is a prime concern in this competitive market.

The following pages will introduce you to consider the capabilities of our staff and our history of quality gaging as it relates to your individual problem areas.

If you are already a customer, we would like to take this opportunity to thank you for your patronage. **Penneyer-Dodge Company** values the opportunity to continue serving you for all your gaging needs.

Hazel L. Dodge

Robert Dodge

SALES AND SERVICE

When you buy from **Penneyer-Dodge Company** you're buying proven quality and reliability. Our knowledgeable sales and engineering staff offer expert phone service in sales and technical information. We invite you to phone our Toll Free Number (**1-800-736-4243**) and let our staff assist you with your gaging requirements.

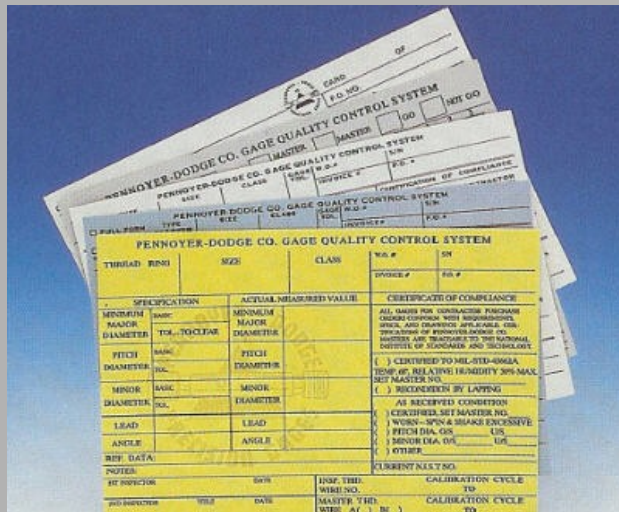

QUALITY CONTROL

Penneyer-Dodge Company maintains a strict quality control program to insure the accuracy of its measurements. There is an in-process surveillance throughout the manufacturing process that insures the quality of our product. Final inspection is performed on all gauges by trained technicians in our environmentally controlled labs.

All **Penneyer-Dodge Company** final inspection equipment is recalibrated on a designated recall schedule. The accuracy of all our final inspection equipment, measuring blocks and thread wires, are traceable to N.I.S.T. **Penneyer-Dodge Company** maintains a quality control manual which adheres to the most stringent government requirements.

CALIBRATION AND RECONDITIONING SERVICE

To aid customers in the calibration requirements of ISO 10012-1, ANSI/NCSS Z540-1, Mil-Std-45662A, **Penneyer-Dodge Company** supplies complete certificates of calibration for all gages traceable to N.I.S.T. These certificates contain basic as well as actual measured values. Used gage certifications show not only the as-found values, but if reconditioned, we also include the new in-tolerance values. Sizable cost and time saving can be achieved through this reconditioning process.





Pennoyer-Dodge Co.

Welcome to Pennoyer-Dodge Company!

SALES AND SERVICE

When you buy from **Pennoyer-Dodge Company** you're buying proven quality and reliability. Our knowledgeable sales and engineering staff offer expert phone service in sales and technical information. We invite you to phone our Toll Free Number (**1-800-736-4243**) and let our staff assist you with your gaging requirements.

CALIBRATION AND RECONDITIONING SERVICE

To aid customers in the calibration requirements of ISO 10012-1, ANSI/NC SL Z540-1, Mil-Std-45662A, **Pennoyer-Dodge Company** supplies complete certificates of calibration for all gages traceable to N.I.S.T. These certificates contain basic as well as actual measured values. Used gage certifications show not only the as-found values, but if reconditioned, we also include the new in-tolerance values. Sizable cost and time saving can be achieved through this reconditioning process.

QUALITY CONTROL

Pennoyer-Dodge Company maintains a strict quality control program to insure the accuracy of its measurements. There is a in-process surveillance throughout the manufacturing process that insures the quality of our product. Final inspection is performed on all gauges by trained technicians in our environmentally controlled labs.

All **Pennoyer-Dodge Company** final inspection equipment is recalibrated on a designated recall schedule. The accuracy of all our final inspection equipment, measuring blocks and thread wires, are traceable to N.I.S.T. **Pennoyer-Dodge Company** maintains a quality control manual which adheres to the most stringent government requirements.



Pennoyer-Dodge Company

When you need it right and right away!

Accepted Methods of Payment
COD,

Net 30 days from date of invoice (upon credit approval),



Table of Contents

Expedite Service	4	NPT Taper Pipe Ring & Plug Gages	23
Taperlock Thread Gages	5 - 7	Cylindrical Taperlock Gages	24
Reversible Thread Plug Gages	8	Cylindrical Reversible Gages	25
S.T.I. Thread Plug Gages X-Tolerance	9	Cylindrical Trilock Gages	26
Standard Thread Ring Gages	10 - 11	Cylindrical Progressive Gages	27
Truncated Setting Plug Gages	12 - 14	Cylindrical Ring Gages	28
Progressive Setting Plug Gages	15 - 16	Standard Calibration/Certification Charges	29
Metric Thread Plug Gages	17	Special Gage Listing	30
Metric Reversible Plug Gages	18	Before Plate Formulas	31
Metric Thread Ring Gages	19	Twister Gages	32
Metric Truncated Setting Plug Gages	20	Twister Out	33
NPTF Taper Pipe Ring & Plug Gages	21	Twister In	34
ANPT Taper Pipe Ring & Plug Gages	22		

PRICES SUBJECT TO CHANGE WITHOUT NOTICE 7/1/2012

- 3 -

PENNOYER-DODGE CO.

1-800-736-4243

818-547-2100

Fax 1-818-240-5719



Pennoyer-Dodge Co.

Our
I Need It Now!
Expedite Service



- Where time is of the essence and normal delivery schedules won't do...
- We will be glad to help you with your "just in time" gaging needs...
- Try our *I NEED IT NOW* 24 & 48 hour Expediting Service.
- Call our technical sales staff and let us know your specific requirements.

1-800-736-4243



Pennoyer-Dodge Co. Taperlock Thread Plug Gages

American Gage Design / Short & Long Form Calibration Reports Available

How To Order

1. State Quantity desired.
2. Nominal size and threads per inch and class of fit.
Example: 1/4-28 UNF-2B
3. Go or Not Go or a complete double end.
4. Handles: Either single end or double end / special marking may be added for

**Call Toll Free
1-800-736-4243**

- an additional charge. (\$12.00 min). Handles ordered in colors other than Red or Green add \$16.00 per handle.
5. Short Form c of c @ n/c. Long Form Calibration Reports add \$16.00 per member.
 6. Calibration stickers available @ \$3.50 per sticker (advise calibration cycle).
 7. CHROME: Add 30% to each member.
 8. "J" Series thread: Add \$6.00 per plug member.

CLASS X RIGHT HAND TAPERLOCK THREAD PLUG GAGES

Nominal Size	Go or Not Go 2B or 3B Members	Complete Double End Gage w/Handle	Handle Only	Handle Size
# 0-80 UNF	43.00	97.00	11.00	#000
# 1-64 UNC	42.00	95.00	11.00	# 000
# 1-72 UNF	42.00	95.00	11.00	# 000
# 2-56 UNC	40.00	91.00	11.00	# 000
# 2-64 UNF	40.00	91.00	11.00	# 000
# 3-48 UNC	38.00	87.00	11.00	# 000
# 3-56 UNF	38.00	87.00	11.00	# 000
# 4-40 UNC	35.00	81.00	11.00	# 00
# 4-48 UNF	36.00	83.00	11.00	# 00
# 5-40 UNC	34.00	79.00	11.00	# 00
# 5-44 UNF	35.00	81.00	11.00	# 00
# 6-32 UNC	32.00	75.00	11.00	# 00
# 6-40 UNF	32.00	75.00	11.00	# 00
# 8-32 UNC	32.00	75.00	11.00	# 0
# 8-36 UNF	32.00	75.00	11.00	# 0
# 10-24 UNC	32.00	75.00	11.00	# 0
# 10-32 UNF	32.00	75.00	11.00	# 0
# 12-24 UNC	33.00	77.00	11.00	# 0
# 12-28 UNF	33.00	77.00	11.00	# 0
# 12-32 UNEF	51.00	113.00	11.00	# 0
1/4-20 UNC	30.00	71.00	11.00	# 1
1/4-28 UNF	30.00	71.00	11.00	# 1
1/4-32 UNEF	50.00	111.00	11.00	# 1
5/16-18 UNC	30.00	71.00	11.00	# 1
5/16-24 UNF	30.00	71.00	11.00	# 1
5/16-32 UNEF	51.00	113.00	11.00	# 1
3/8-16 UNC	31.00	73.00	11.00	# 2
3/8-24 UNF	31.00	73.00	11.00	# 2
3/8-32 UNEF	58.00	127.00	11.00	# 2
7/16-14 UNC	31.00	73.00	11.00	# 2
7/16-20 UNF	31.00	73.00	11.00	# 2



PRICES SUBJECT TO CHANGE WITHOUT NOTICE 7/1/2012

- 5 -



Pennoyer-Dodge Co. Taperlock Thread Plug Gages

American Gage Design / Short & Long Form Calibration Reports Available

How To Order

1. State Quantity desired.
2. Nominal size and threads per inch and class of fit.
Example: 1/4-28 UNF-2B
3. Go or Not Go or a complete double end.
4. Handles: Either single end or double end / special marking may be added for

Call Toll Free
1-800-736-4243

- an additional charge. (\$12.00 min). Handles ordered in colors other than Red or Green add \$16.00 per handle.
5. Short Form c of c @ n/c. Long Form Calibration Reports add \$16.00 per member.
 6. Calibration stickers available @ \$3.50 per sticker (advise calibration cycle).
 7. CHROME: Add 30% to each member.
 8. "J" Series thread: Add \$6.00 per plug member.

CLASS X RIGHT HAND TAPERLOCK THREAD PLUG GAGES

Nominal Size	Go or Not Go 2B or 3B Members	Complete Double End Gage w/Handle	Handle Only	Handle Size
7/16-28 UNEF	58.00	127.00	11.00	# 2
1/2-13 UNC	32.00	75.00	11.00	# 2
1/2-20 UNF	32.00	75.00	11.00	# 2
1/2-28 UNEF	59.00	129.00	11.00	# 2
9/16-12 UNC	40.00	91.00	11.00	# 3
9/16-18 UNF	40.00	91.00	11.00	# 3
9/16-24 UNEF	64.00	139.00	11.00	# 3
5/8-11 UNC	40.00	91.00	11.00	# 3
5/8-18 UNF	40.00	91.00	11.00	# 3
5/8-24 UNEF	65.00	141.00	11.00	# 3
11/16-24 UNEF	65.00	141.00	11.00	# 3
3/4-10 UNC	44.00	99.00	11.00	# 3
3/4-16 UNF	44.00	99.00	11.00	# 3
3/4-20 UNEF	67.00	145.00	11.00	# 3
13/16-20 UNEF	76.00	163.00	11.00	# 3
7/8-9 UNC	46.00	103.00	11.00	# 4
7/8-14 UNF	46.00	103.00	11.00	# 4
7/8-20 UNEF	78.00	167.00	11.00	# 4
15/16-20 UNEF	79.00	169.00	11.00	# 4
1-8 UNC	56.00	123.00	11.00	# 4
1-12 UNF	56.00	123.00	11.00	# 4
1-14 UNS	56.00	123.00	11.00	# 4
1-20 UNEF	87.00	185.00	11.00	# 4
1 1/16-18 UNEF	88.00	187.00	11.00	# 4
1 1/8-7 UNC	69.00	149.00	11.00	# 4
1 1/8-12 UNF	69.00	149.00	11.00	# 4
1 1/8-18 UNEF	88.00	187.00	11.00	# 4
1 3/16-18 UNEF	95.00	202.00	12.00	# 5
1 1/4-7 UNC	74.00	160.00	12.00	# 5
1 1/4-12 UNF	72.00	156.00	12.00	# 5
1 1/4-18 UNEF	100.00	212.00	12.00	# 5



PRICES SUBJECT TO CHANGE WITHOUT NOTICE 7/1/2012

- 6 -

PENNOYER-DODGE CO.

1-800-736-4243

818-547-2100

Fax 1-818-240-5719



Pennoyer-Dodge Co. Taperlock Thread Plug Gages

American Gage Design / Short & Long Form Calibration Reports Available

How To Order

1. State Quantity desired.
2. Nominal size and threads per inch and class of fit.
Example: 1/4-28 UNF-2B
3. Go or Not Go or a complete double end.
4. Handles: Either single end or double end / special marking may be added for

Call Toll Free
1-800-736-4243

- an additional charge. (\$12.00 min). Handles ordered in colors other than Red or Green add \$16.00 per handle.
5. Short Form c of c @ n/c. Long Form Calibration Reports add \$16.00 per member.
 6. Calibration stickers available @ \$3.50 per sticker (advise calibration cycle).
 7. CHROME: Add 30% to each member.
 8. "J" Series thread: Add \$6.00 per plug member.

CLASS X RIGHT HAND
TAPERLOCK THREAD PLUG GAGES

Nominal Size	Go or Not Go 2B or 3B Members	Complete Double End Gage w/Handle	Handle Only	Handle Size
1 5/16-18 UNEF	102.00	216.00	12.00	# 5
1 3/8-6 UNC	84.00	180.00	12.00	# 5
1 3/8-12 UNF	80.00	172.00	12.00	# 5
1 3/8-18 UNEF	107.00	226.00	12.00	# 5
1 7/16-18 UNEF	109.00	230.00	12.00	# 5
1 1/2-6 UNC	92.00	196.00	12.00	# 5
1 1/2-12 UNF	90.00	192.00	12.00	# 5
1 1/2-18 UNEF	114.00	240.00	12.00	# 5





Pennoyer-Dodge Co. Reversible Thread Plug Gages

American Gage Design / Short & Long Form Calibration Reports Available

How To Order

1. State Quantity desired.
2. Nominal size and threads per inch and class of fit.
Example: 1/4-28 UNF-2B
3. Go or Not Go or a complete double end.
4. Handles: Either single end or double end.

**Call Toll Free
1-800-736-4243**

- Handles ordered in colors other than Red or Green collets and other than plain handles, call for current pricing.
5. Special marking may be added for an additional charge. (\$12.00 min).
 6. Short Form c of c @ n/c. Long Form Calibration Reports add \$16.00 per member.
 7. Calibration stickers available @ \$3.50 per sticker (advise calibration cycle).
 8. CHROME: Add 30% to each member.
 9. If Trilock style desired from .760 to 1.500, price upon application.

CLASS X RIGHT HAND REVERSIBLE THREAD PLUGGAGES

Nominal Size	Go or Not Go 2B or 3B Members	Complete Double End Gage w/Handle	Handle Only	Handle Size
# 0-80 UNF	65.00	144.00	14.00	# 1w
# 1-64 UNC	63.00	140.00	14.00	# 1w
# 1-72 UNF	61.00	136.00	14.00	# 1w
# 2-56 UNC	59.00	132.00	14.00	# 2w
# 2-64 UNF	59.00	132.00	14.00	# 2w
# 3-48 UNC	59.00	132.00	14.00	# 2w
# 3-56 UNF	59.00	132.00	14.00	# 2w
# 4-40 UNC	53.00	120.00	14.00	# 2w
# 4-48 UNF	53.00	120.00	14.00	# 2w
# 5-40 UNC	53.00	120.00	14.00	# 2w
# 5-44 UNF	53.00	120.00	14.00	# 2w
# 6-32 UNC	48.00	110.00	14.00	# 2w
# 6-40 UNF	48.00	110.00	14.00	# 2w
# 8-32 UNC	48.00	110.00	14.00	# 2w
# 8-36 UNF	48.00	110.00	14.00	# 2w
# 10-24 UNC	48.00	112.00	16.00	# 3w
# 10-32 UNF	48.00	112.00	16.00	# 3w
# 12-24 UNC	48.00	112.00	16.00	# 3w
# 12-28 UNF	48.00	112.00	16.00	# 3w
1/4-20 UNC	45.00	106.00	16.00	# 3w
1/4-28 UNF	45.00	106.00	16.00	# 3w
5/16-18 UNC	45.00	107.00	17.00	# 4w
5/16-24 UNF	45.00	107.00	17.00	# 4w
3/8-16 UNC	45.00	107.00	17.00	# 4w
3/8-24 UNF	45.00	107.00	17.00	# 4w
7/16-14 UNC	47.00	113.00	19.00	# 5w
7/16-20 UNF	45.00	109.00	19.00	# 5w
1/2-13 UNC	48.00	115.00	19.00	# 5w
1/2-20 UNF	48.00	115.00	19.00	# 5w
9/16-12 UNC	55.00	131.00	21.00	# 6w
9/16-18 UNF	55.00	131.00	21.00	# 6w
5/8-11 UNC	57.00	135.00	21.00	# 6w
5/8-18 UNF	57.00	135.00	21.00	# 6w
3/4-10 UNC	62.00	147.00	23.00	# 7w
3/4-16 UNF	62.00	147.00	23.00	# 7w



PRICES SUBJECT TO CHANGE WITHOUT NOTICE 7/1/2012A

- 8 -

PENNOYER-DODGE CO.

1-800-736-4243

818-547-2100

Fax 1-818-240-5719



Pennoyer-Dodge Co.

S.T.I. Thread Plug Gages X-Tolerance

American Gage Design / Short & Long Form Calibration Reports Available

How To Order

1. State Quantity desired.
2. Nominal size and threads per inch and class of fit.
Example: 1/4-28 UNF-2B S.T.I.
3. Go or Not Go or a complete double end.
4. Handles: Either single end or double end. Handles ordered in colors other

Call Toll Free
1-800-736-4243

5. than Red or Green add \$15.00 per handle.
6. Special marking may be added for an additional charge. (\$12.00 min).
7. Short Form c of c @ n/c. Long Form Calibration Reports add \$16.00 per member.
8. Calibration stickers available @ \$3.50 per sticker (advise calibration cycle).
9. "W" tolerance (Inspection Grade) add 30% to each member.
10. CHROME: Add 30% to each member.

CLASS X RIGHT HAND
S.T.I. THREAD PLUG GAGES

Nominal Size	Go or 2B or 3B Not Go Member	Complete Double End 2B or 3B Gage w/Handle	Handle Only	Handle Size
# 2-56 UNC	58.00	127.00	11.00	# 00
# 4-40 UNC	48.00	107.00	11.00	# 00
# 4-48 UNF	50.00	111.00	11.00	# 00
# 6-32 UNC	48.00	107.00	11.00	# 0
# 6-40 UNF	50.00	111.00	11.00	# 0
# 8-32 UNC	48.00	107.00	11.00	# 0
# 10-24 UNC	48.00	107.00	11.00	# 0
# 10-32 UNF	46.00	103.00	11.00	# 0
1/4-20 UNC	45.00	101.00	11.00	# 1
1/4-28 UNF	43.00	97.00	11.00	# 1
5/16-18 UNC	45.00	101.00	11.00	# 2
5/16-24 UNF	43.00	97.00	11.00	# 1
3/8-16 UNC	47.00	105.00	11.00	# 2
3/8-24 UNF	45.00	101.00	11.00	# 2
7/16-14 UNC	47.00	105.00	11.00	# 3
7/16-20 UNF	45.00	101.00	11.00	# 2
1/2-13 UNC	50.00	111.00	11.00	# 3
1/2-20 UNF	48.00	107.00	11.00	# 3





Pennoyer-Dodge Co. Standard Thread Rings Gages

American Gage Design / Short & Long Form Calibration Reports Available

How To Order

1. State Quantity desired.
2. Nominal size and threads per inch and class of fit.
Example: 1/4-28 UNF-2A
3. Go or Not Go or a set of gages.

Call Toll Free
1-800-736-4243

4. Special marking for an additional charge.(\$12.00 min.)
5. Short Form c of c @ n/c. Long Form Calibration Reports add \$16.00 per ring.
6. Calibration stickers available @ \$3.50 per sticker (advise calibration cycle).
7. CHROME: Add 50% for sizes #10 and up, per ring.
8. For "J" series (MIL-S-8879 and SAE-AS-71051), add \$55.00 per GO ring.

CLASS X RIGHT HAND AGD THREAD RING GAGES

Nominal Size	Go or Not Go 2A or 3A	Go & Not Go Sets 2A or 3A	Ring Holder	Ring Holder Size
# 0-80 UNF	124.00	248.00	18.00	1T
# 1-64 UNC	114.00	228.00	18.00	1T
# 1-72 UNF	114.00	228.00	18.00	1T
# 2-56 UNC	108.00	216.00	18.00	1T
# 2-64 UNF	108.00	216.00	18.00	1T
# 3-48 UNC	108.00	216.00	18.00	1T
# 3-56 UNF	108.00	216.00	18.00	1T
# 4-40 UNC	99.00	198.00	18.00	1T
# 4-48 UNF	99.00	198.00	18.00	1T
# 5-40 UNC	87.00	174.00	18.00	1T
# 5-44 UNF	87.00	174.00	18.00	1T
# 6-32 UNC	87.00	174.00	18.00	1T
# 6-40 UNF	87.00	174.00	18.00	1T
# 8-32 UNC	84.00	168.00	18.00	1T
# 8-36 UNF	84.00	168.00	18.00	1T
# 10-24 UNC	84.00	168.00	18.00	1T
# 10-32 UNF	84.00	168.00	18.00	1T
# 12-24 UNC	84.00	168.00	18.00	1T
# 12-28 UNF	84.00	168.00	18.00	1T
# 12-32 UNEF	110.00	220.00	18.00	1T
1/4-20 UNC	83.00	166.00	18.00	2T
1/4-28 UNF	83.00	166.00	18.00	2T
1/4-32 UNEF	110.00	220.00	18.00	2T
5/16-18 UNC	83.00	166.00	18.00	2T
5/16-24 UNF	83.00	166.00	18.00	2T
5/16-32 UNEF	110.00	220.00	18.00	2T
3/8-16 UNC	86.00	172.00	18.00	3T
3/8-24 UNF	86.00	172.00	18.00	3T
3/8-32 UNEF	110.00	220.00	18.00	3T
7/16-14 UNC	87.00	174.00	18.00	3T
7/16-20 UNF	86.00	172.00	18.00	3T
7/16-28 UNEF	110.00	220.00	18.00	3T
1/2-13 UNC	89.00	178.00	18.00	3T
1/2-20 UNF	88.00	176.00	18.00	3T
1/2-28 UNEF	115.00	230.00	18.00	3T
9/16-12 UNC	106.00	212.00	24.00	4T
9/16-18 UNF	106.00	212.00	24.00	4T



PRICES SUBJECT TO CHANGE WITHOUT NOTICE

7/1/2012

- 10

PENNOYER-DODGE CO.

1-800-736-4243

818-547-2100

Fax 1-818-240-5719



Pennoyer-Dodge Co. Standard Thread Rings Gages

American Gage Design / Short & Long Form Calibration Reports Available

How To Order

1. State Quantity desired.
2. Nominal size and threads per inch and class of fit.
Example: 1/4-28 UNF-2A
3. Go or Not Go or a set of gages.

Call Toll Free
1-800-736-4243

4. Special marking for an additional charge.(\$12.00 min.)
5. Short Form c of c @ n/c. Long Form Calibration Reports add \$16.00 per ring.
6. Calibration stickers available @ \$3.50 per sticker (advise calibration cycle).
7. CHROME: Add 50% for sizes #10 and up, per ring.
8. For "J" series (MIL-S-8879 and SAE-AS-71051), add \$55.00 per GO ring.

CLASS X RIGHT HAND AGD THREAD RING GAGES

Nominal Size	Go or Not Go 2A or 3A	Go & Not Go Sets 2A or 3A	Ring Holder	Ring Holder Size
9/16-24 UNEF	115.00	230.00	24.00	4T
5/8-11 UNC	106.00	212.00	24.00	4T
5/8-18 UNF	104.00	208.00	24.00	4T
5/8-24 UNEF	136.00	272.00	24.00	4T
11/16-24 UNEF	136.00	272.00	24.00	4T
3/4-10 UNC	129.00	258.00	24.00	4T
3/4-16 UNF	129.00	258.00	24.00	4T
3/4-20 UNEF	155.00	310.00	24.00	4T
13/16-20 UNEF	160.00	320.00	24.00	4T
7/8-9 UNC	140.00	280.00	28.00	5T
7/8-14 UNF	140.00	280.00	28.00	5T
7/8-20 UNEF	168.00	336.00	28.00	5T
15/16-20 UNEF	168.00	336.00	28.00	5T
1-8 UNC	170.00	340.00	28.00	5T
1-12 UNF	170.00	340.00	28.00	5T
1-14 UNS	170.00	340.00	28.00	5T
1-20 UNEF	195.00	390.00	28.00	5T
1 1/16-18 UNEF	210.00	420.00	28.00	5T
1 1/8-7 UNC	210.00	420.00	28.00	5T
1 1/8-12 UNF	210.00	420.00	28.00	5T
1 1/8-18 UNEF	225.00	450.00	28.00	5T
1 3/16-18 UNEF	230.00	460.00	33.00	6T
1 1/4-7 UNC	228.00	456.00	33.00	6T
1 1/4-12 UNF	228.00	456.00	33.00	6T
1 1/4-18 UNEF	233.00	466.00	33.00	6T
1 5/16-18 UNEF	233.00	466.00	33.00	6T
1 3/8-6 UNC	233.00	466.00	33.00	6T
1 3/8-12 UNF	233.00	466.00	33.00	6T
1 3/8-18 UNEF	247.00	494.00	33.00	6T
1 7/16-18 UNEF	250.00	500.00	33.00	6T
1 1/2-6 UNC	250.00	500.00	33.00	6T
1 1/2-12 UNF	250.00	500.00	33.00	6T
1 1/2-18 UNEF	265.00	530.00	33.00	6T





Pennoyer-Dodge Co.

Truncated Setting Plug Gages

American Gage Design / Short & Long Form Calibration Reports Available

How To Order

1. State Quantity desired.
2. Nominal size and threads per inch and class of fit.
Example: 1/4-28 UNF-2A
3. Go or Not Go or a complete double end.
4. Handles: Either single end or double end. Handles ordered in colors other

Call Toll Free
1-800-736-4243

- than Red or Green add \$15.00 per handle.
5. Special marking may be added for an additional charge. (\$12.00 min).
6. Short Form c of c @ n/c. Long Form Calibration Reports add \$16.00 per member.
7. Calibration stickers available @ \$3.50 per sticker (advise calibration cycle).
8. W-Tolerance P.D. add 30% per member.
9. "J" Series thread: Add \$6.00 per plug member.
10. Full Form set plugs available upon request.

CLASS X P.D. RIGHT HAND TRUNCATED SETTING
PLUG GAGES W-TOL ON LEAD & ANGLE

Nominal Size	Go or Not Go 2A or 3A Members	Complete Double End Gage w/Handle	Handle Only	Handle Size
# 0-80 UNF	88.00	187.00	11.00	# 000
# 1-64 UNC	88.00	187.00	11.00	# 000
# 1-72 UNF	88.00	187.00	11.00	# 000
# 2-56 UNC	88.00	187.00	11.00	# 000
# 2-64 UNF	88.00	187.00	11.00	# 000
# 3-48 UNC	80.00	171.00	11.00	# 000
# 3-56 UNF	80.00	171.00	11.00	# 000
# 4-40 UNC	77.00	165.00	11.00	# 00
# 4-48 UNF	77.00	165.00	11.00	# 00
# 5-40 UNC	68.00	147.00	11.00	# 00
# 5-44 UNF	68.00	147.00	11.00	# 00
# 6-32 UNC	68.00	147.00	11.00	# 00
# 6-40 UNF	68.00	147.00	11.00	# 00
# 8-32 UNC	68.00	147.00	11.00	# 0
# 8-36 UNF	68.00	147.00	11.00	# 0
# 10-24 UNC	68.00	147.00	11.00	# 0
# 10-32 UNF	68.00	147.00	11.00	# 0
# 12-24 UNC	73.00	157.00	11.00	# 0
# 12-28 UNF	73.00	157.00	11.00	# 0
# 12-32 UNEF	88.00	187.00	11.00	# 0
1/4-20 UNC	63.00	137.00	11.00	# 1
1/4-28 UNF	63.00	137.00	11.00	# 1
1/4-32 UNEF	89.00	189.00	11.00	# 1
5/16-18 UNC	63.00	137.00	11.00	# 1
5/16-24 UNF	63.00	137.00	11.00	# 1
5/16-32 UNEF	90.00	191.00	11.00	# 1
3/8-16 UNC	64.00	139.00	11.00	# 2
3/8-24 UNF	64.00	139.00	11.00	# 2
3/8-32 UNEF	103.00	217.00	11.00	# 2
7/16-14 UNC	69.00	149.00	11.00	# 2



PRICES SUBJECT TO CHANGE WITHOUT NOTICE 7/1/2012

- 12



Pennoyer-Dodge Co.

Truncated Setting Plug Gages

American Gage Design / Short & Long Form Calibration Reports Available

How To Order

1. State Quantity desired.
2. Nominal size and threads per inch and class of fit.
Example: 1/4-28 UNF-2A
3. Go or Not Go or a complete double end.
4. Handles: Either single end or double end. Handles ordered in colors other

Call Toll Free
1-800-736-4243

- than Red or Green add \$15.00 per handle.
5. Special marking may be added for an additional charge. (\$12.00 min).
6. Short Form c of c @ n/c. Long Form Calibration Reports add \$16.00 per member.
7. Calibration stickers available @ \$3.50 per sticker (advise calibration cycle).
8. W-Tolerance P.D. add 30% per member.
9. "J" Series thread: Add \$6.00 per plug member.
10. Full Form set plugs available upon request.

CLASS X P.D. RIGHT HAND TRUNCATED SETTING
PLUG GAGES W-TOL ON LEAD & ANGLE

Nominal Size	Go or Not Go 2A or 3A Members	Complete Double End Gage w/Handle	Handle Only	Handle Size
7/16-20 UNF	69.00	149.00	11.00	# 2
7/16-28 UNEF	103.00	217.00	11.00	# 2
1/2-13 UNC	71.00	153.00	11.00	# 2
1/2-20 UNF	71.00	153.00	11.00	# 2
1/2-28 UNEF	112.00	235.00	11.00	# 2
9/16-12 UNC	81.00	173.00	11.00	# 3
9/16-18 UNF	81.00	173.00	11.00	# 3
9/16-24 UNEF	120.00	251.00	11.00	# 3
5/8-11 UNC	84.00	179.00	11.00	# 3
5/8-18 UNF	84.00	179.00	11.00	# 3
5/8-24 UNEF	120.00	251.00	11.00	# 3
11/16-24 UNEF	130.00	271.00	11.00	# 3
3/4-10 UNC	98.00	207.00	11.00	# 3
3/4-16 UNF	98.00	207.00	11.00	# 3
3/4-20 UNEF	130.00	271.00	11.00	# 3
13/16-20 UNEF	135.00	281.00	11.00	# 3
7/8-9 UNC	115.00	241.00	11.00	# 4
7/8-14 UNF	115.00	241.00	11.00	# 4
7/8-20 UNEF	138.00	287.00	11.00	# 4
15/16-20 UNEF	139.00	289.00	11.00	# 4
1-8 UNC	130.00	271.00	11.00	# 4
1-12 UNF	130.00	271.00	11.00	# 4
1-14 UNS	130.00	271.00	11.00	# 4
1-20 UNEF	147.00	305.00	11.00	# 4
1 1/16-18 UNEF	148.00	307.00	11.00	# 4
1 1/8-7 UNC	147.00	305.00	11.00	# 4
1 1/8-12 UNF	147.00	305.00	11.00	# 4
1 1/8-18 UNEF	160.00	331.00	11.00	# 4
1 3/16-18 UNEF	162.00	336.00	12.00	# 5
1 1/4-7 UNC	160.00	332.00	12.00	# 5



PRICES SUBJECT TO CHANGE WITHOUT NOTICE 7/1/2012

- 13



Pennoyer-Dodge Co. Truncated Setting Plug Gages

American Gage Design / Short & Long Form Calibration Reports Available

How To Order

1. State Quantity desired.
2. Nominal size and threads per inch and class of fit.
Example: 1/4-28 UNF-2A
3. Go or Not Go or a complete double end.
4. Handles: Either single end or double end. Handles ordered in colors other

**Call Toll Free
1-800-736-4243**

- than Red or Green add \$15.00 per handle.
5. Special marking may be added for an additional charge. (\$12.00 min).
6. Short Form c of c @ n/c. Long Form Calibration Reports add \$16.00 per member.
7. Calibration stickers available @ \$3.50 per sticker (advise calibration cycle).
8. W-Tolerance P.D. add 30% per member.
9. "J" Series thread: Add \$6.00 per plug member.
10. Full Form set plugs available upon request.

CLASS X P.D. RIGHT HAND TRUNCATED SETTING PLUG GAGES W-TOL ON LEAD & ANGLE

Nominal Size	Go or Not Go 2A or 3A Members	Complete Double End Gage w/Handle	Handle Only	Handle Size
1 1/4-12 UNF	160.00	332.00	12.00	# 5
1 1/4-18 UNEF	178.00	368.00	12.00	# 5
1 5/16-18 UNEF	178.00	368.00	12.00	# 5
1 3/8-6 UNC	186.00	384.00	12.00	# 5
1 3/8-12 UNF	186.00	384.00	12.00	# 5
1 3/8-18 UNEF	195.00	402.00	12.00	# 5
1 7/16-18 UNEF	199.00	410.00	12.00	# 5
1 1/2-6 UNC	198.00	408.00	12.00	# 5
1 1/2-12 UNF	198.00	408.00	12.00	# 5
1 1/2-18 UNEF	207.00	426.00	12.00	# 5





Pennoyer-Dodge Co.

*Progressive Setting Plug Gages

American Gage Design / Short & Long Form Calibration Reports Available

How To Order

1. State Quantity desired.
2. Nominal size and threads per inch and class of fit.
Example: 1/4-28 UNF-2A Progressive
3. Go or Not Go or a complete double end.
4. Handles: Either single end or double end. Handles ordered in colors other than Red or Green add \$15.00 per handle.

**Call Toll Free
1-800-736-4243**

5. Special marking may be added for an additional charge. (\$12.00 min)
6. Short Form c of c @ n/c. Long Form Calibration Reports add \$32.00 per member.
7. Calibration stickers available @ \$3.50 per sticker (advise calibration cycle).

CLASS X P.D. RIGHT HAND PROGRESSIVE SETTING
PLUG GAGES W-TOL ON LEAD & ANGLE

Nominal Size	Go or Not Go 2A or 3A Members	Complete Double End Gage w/Handle	Handle Only	Handle Size
# 0-80 UNF	124.00	259.00	11.00	# 000
# 1-64 UNC	124.00	259.00	11.00	# 000
# 1-72 UNF	124.00	259.00	11.00	# 000
# 2-56 UNC	124.00	259.00	11.00	# 000
# 2-64 UNF	124.00	259.00	11.00	# 000
# 3-48 UNC	114.00	239.00	11.00	# 000
# 3-56 UNF	114.00	239.00	11.00	# 000
# 4-40 UNC	114.00	239.00	11.00	# 00
# 4-48 UNF	114.00	239.00	11.00	# 00
# 5-40 UNC	104.00	219.00	11.00	# 00
# 5-44 UNF	104.00	219.00	11.00	# 00
# 6-32 UNC	104.00	219.00	11.00	# 00
# 6-40 UNF	104.00	219.00	11.00	# 00
# 8-32 UNC	104.00	219.00	11.00	# 0
# 8-36 UNF	104.00	219.00	11.00	# 0
# 10-24 UNC	104.00	219.00	11.00	# 0
# 10-32 UNF	104.00	219.00	11.00	# 0
# 12-24 UNC	104.00	219.00	11.00	# 0
# 12-28 UNF	104.00	219.00	11.00	# 0
# 12-32 UNEF	130.00	271.00	11.00	# 0
1/4-20 UNC	87.00	185.00	11.00	# 1
1/4-28 UNF	87.00	185.00	11.00	# 1
1/4-32 UNEF	118.00	247.00	11.00	# 1
5/16-18 UNC	87.00	185.00	11.00	# 1
5/16-24 UNF	87.00	185.00	11.00	# 1
5/16-32 UNEF	129.00	269.00	11.00	# 1
3/8-16 UNC	93.00	197.00	11.00	# 2
3/8-24 UNF	93.00	197.00	11.00	# 2
3/8-32 UNEF	141.00	293.00	11.00	# 2
7/16-14 UNC	93.00	197.00	11.00	# 2
7/16-20 UNF	93.00	197.00	11.00	# 2
7/16-28 UNEF	141.00	293.00	11.00	# 2
1/2-13 UNC	101.00	213.00	11.00	# 2
1/2-20 UNF	101.00	213.00	11.00	# 2
1/2-28 UNEF	146.00	303.00	11.00	# 2



* Progressive master setting plugs differ from conventional truncated setting plugs in that the plug member contains two distinct P.D. limit areas. The limits are based on the Min. and Max. P.D. limits for the ring gage it will be used to inspect. The front portion contains the minimum P.D. limit with a full form major diameter, while the back portion contains the maximum P.D. limit with a truncated major diameter.

PRICES SUBJECT TO CHANGE WITHOUT NOTICE 7/1/2012

- 15



Pennoyer-Dodge Co.

*Progressive Setting Plug Gages

American Gage Design / Short & Long Form Calibration Reports Available

How To Order

1. State Quantity desired.
2. Nominal size and threads per inch and class of fit.
Example: 1/4-28 UNF-2A Progressive
3. Go or Not Go or a complete double end.
4. Handles: Either single end or double end. Handles ordered in colors other than Red or Green add \$15.00 per handle.

Call Toll Free
1-800-736-4243

5. Special marking may be added for an additional charge. (\$12.00 min)
6. Short Form c of c @ n/c. Long Form Calibration Reports add \$32.00 per member.
7. Calibration stickers available @ \$3.50 per sticker (advise calibration cycle).

CLASS X P.D. RIGHT HAND PROGRESSIVE SETTING
PLUG GAGES W-TOL ON LEAD & ANGLE

Nominal Size	Go or Not Go 2A or 3A Members	Complete Double End Gage w/Handle	Handle Only	Handle Size
9/16-12 UNC	112.00	235.00	11.00	# 3
9/16-18 UNF	110.00	231.00	11.00	# 3
9/16-24 UNEF	148.00	307.00	11.00	# 3
5/8-11 UNC	117.00	245.00	11.00	# 3
5/8-18 UNF	110.00	231.00	11.00	# 3
5/8-24 UNEF	151.00	313.00	11.00	# 3
11/16-24 UNEF	153.00	317.00	11.00	# 3
3/4-10 UNC	131.00	273.00	11.00	# 3
3/4-16 UNF	127.00	265.00	11.00	# 3
3/4-20 UNEF	155.00	321.00	11.00	# 3
13/16-20 UNEF	173.00	357.00	11.00	# 3
7/8-9 UNC	140.00	291.00	11.00	# 4
7/8-14 UNF	132.00	275.00	11.00	# 4
7/8-20 UNEF	179.00	369.00	11.00	# 4
15/16-20 UNEF	185.00	381.00	11.00	# 4
1-8 UNC	173.00	357.00	11.00	# 4
1-12 UNF	165.00	341.00	11.00	# 4
1-14 UNS	165.00	341.00	11.00	# 4
1-20 UNEF	195.00	401.00	11.00	# 4
1 1/16-18 UNEF	205.00	421.00	11.00	# 4
1 1/8-7 UNC	197.00	405.00	11.00	# 4
1 1/8-12 UNF	186.00	383.00	11.00	# 4
1 1/8-18 UNEF	205.00	421.00	11.00	# 4
1 3/16-18 UNEF	217.00	446.00	12.00	# 5
1 1/4-7 UNC	217.00	446.00	12.00	# 5
1 1/4-12 UNF	208.00	428.00	12.00	# 5
1 1/4-18 UNEF	217.00	446.00	12.00	# 5
1 5/16-18 UNEF	235.00	482.00	12.00	# 5
1 3/8-6 UNC	249.00	510.00	12.00	# 5
1 3/8-12 UNF	232.00	476.00	12.00	# 5
1 3/8-18 UNEF	239.00	490.00	12.00	# 5
1 7/16-18 UNEF	258.00	528.00	12.00	# 5
1 1/2-6 UNC	237.00	486.00	12.00	# 5
1 1/2-12 UNF	237.00	486.00	12.00	# 5
1 1/2-18 UNEF	259.00	530.00	12.00	# 5



* Progressive master setting plugs differ from conventional truncated setting plugs in that the plug member contains two distinct P.D. limit areas. The limits are based on the Min. and Max. P.D. limits for the ring gage it will be used to inspect. The front portion contains the minimum P.D. limit with a full form major diameter, while the back portion contains the maximum P.D. limit with a truncated major diameter.

PRICES SUBJECT TO CHANGE WITHOUT NOTICE 7/1/2012

- 16

PENNOYER-DODGE CO.

1-800-736-4243

818-547-2100

Fax 1-818-240-5719



Pennoyer-Dodge Co. Metric Thread Plug Gages

American Gage Design / Short & Long Form Calibration Reports Available

How To Order

1. State Quantity desired.
2. Nominal size and threads per inch and class of fit.
Example: 10.00 x 1.25-6H
3. Go or Not Go or a complete double end.
4. Handles: Either single end or double end. Handles ordered in colors other

**Call Toll Free
1-800-736-4243**

- than Red or Green add \$15.00 per handle.
5. Special marking may be added for an additional charge. (\$12.00 min).
 6. Short Form c of c @ n/c. Long Form Calibration Reports add \$16.00 per member.
 7. Calibration stickers available @ \$3.50 per sticker (advise calibration cycle).
 8. CHROME: Add 30% to each member.
 9. For "MJ Series", price on application.

CLASS X RIGHT HAND METRIC THREAD PLUG GAGES

Nominal Size	Go or Not Go 6H Members	Complete Double End Gage w/Handle	Handle Only	Handle Size
M1.6 x 0.35	55.00	121.00	11.00	# 000
M2.0 x 0.40	53.00	117.00	11.00	# 000
M2.5 x 0.45	48.00	107.00	11.00	# 000
M3.0 x 0.50	48.00	107.00	11.00	# 00
M3.5 x 0.60	42.00	95.00	11.00	# 00
M4.0 x 0.70	42.00	95.00	11.00	# 0
M5.0 x 0.80	42.00	95.00	11.00	# 0
M6.0 x 1.00	35.00	81.00	11.00	# 0
M8.0 x 1.25	35.00	81.00	11.00	# 1
M10 x 1.00	38.00	87.00	11.00	# 2
M10 x 1.25	38.00	87.00	11.00	# 2
M10 x 1.50	38.00	87.00	11.00	# 2
M12 x 1.25	40.00	91.00	11.00	# 2
M12 x 1.50	40.00	91.00	11.00	# 2
M12 x 1.75	40.00	91.00	11.00	# 2
M14 x 1.50	45.00	101.00	11.00	# 3
M14 x 2.00	45.00	101.00	11.00	# 3
M16 x 1.50	45.00	101.00	11.00	# 3
M16 x 2.00	45.00	101.00	11.00	# 3
M18 x 1.50	50.00	111.00	11.00	# 3
M18 x 2.50	50.00	111.00	11.00	# 3
M20 x 1.00	58.00	127.00	11.00	# 3
M20 x 1.50	57.00	125.00	11.00	# 3
M20 x 2.50	57.00	125.00	11.00	# 3
M22 x 1.50	57.00	125.00	11.00	# 4





Pennoyer-Dodge Co. Metric Reversible Plug Gages

American Gage Design / Short & Long Form Calibration Reports Available

How To Order

1. State Quantity desired.
2. Nominal metric size and metric threads per inch and class of fit.
Example: 10.00 x 1.25-6H
3. Go or Not Go or a complete double end.
4. Handles: Either single end or double end. Handles ordered in colors other than Red or Green collets and other than plain handles, call for current pricing.

**Call Toll Free
1-800-736-4243**

5. Special marking may be added for an additional charge. (\$12.00 min).
6. Short Form c of c @ n/c. Long Form Calibration Reports add \$16.00 per member.
7. Calibration stickers available @ \$3.50 per sticker (advise calibration cycle).
8. CHROME: Add 30% to each member.
9. For "MJ Series", price on application.

CLASS X RIGHT HAND
METRIC REVERSIBLE THREAD PLUG GAGES

Nominal Size	Go or Not Go 6H	Complete Double End Gage	Handle Only	Handle Size
M1.6 x 0.35	78.00	170.00	14.00	# 1W
M2.0 x 0.40	74.00	162.00	14.00	# 2W
M2.5 x 0.45	74.00	162.00	14.00	# 2W
M3.0 x 0.50	66.00	146.00	14.00	# 2W
M3.5 x 0.60	57.00	128.00	14.00	# 2W
M4.0 x 0.70	55.00	124.00	14.00	# 2W
M5.0 x 0.80	55.00	126.00	16.00	# 3W
M6.0 x 1.00	55.00	126.00	16.00	# 3W
M8.0 x 1.25	55.00	127.00	17.00	# 4W
M10 x 1.00	60.00	139.00	19.00	# 5W
M10 x 1.25	49.00	117.00	19.00	# 5W
M10 x 1.50	49.00	117.00	19.00	# 5W
M12 x 1.25	54.00	127.00	19.00	# 5W
M12 x 1.50	54.00	127.00	19.00	# 5W
M12 x 1.75	54.00	127.00	19.00	# 5W

CYLINDRICAL REVERSIBLE GAGES





Pennoyer-Dodge Co. Metric Thread Ring Gages

American Gage Design / Short & Long Form Calibration Reports Available

How To Order

1. State Quantity desired.
2. Nominal metric size and metric threads per inch and class of fit.
Example: 10.00 x 1.25-6g
3. Go or Not Go or a complete set of rings.

**Call Toll Free
1-800-736-4243**

4. Special marking may be added for an additional charge(\$12.00 min).
5. Short Form c of c @ n/c. Long Form Calibration Reports add \$16.00 per ring.
6. Calibration stickers available @ \$3.50 per sticker (advise calibration cycle).
7. CHROME: Add 50% for size 5.0mm and up, per ring.
8. For "MJ Series", price on application.

CLASS X RIGHT HAND METRIC THREAD RING GAGES

Nominal Size	Go or Not Go 6g Members	Go and Not Go 6g Pair of Rings	Ring Holder	Ring Holder Size
M1.6 x 0.35	147.00	294.00	18.00	# 1T
M2.0 x 0.40	126.00	252.00	18.00	# 1T
M2.5 x 0.45	126.00	252.00	18.00	# 1T
M3.0 x 0.50	109.00	218.00	18.00	# 1T
M3.5 x 0.60	109.00	218.00	18.00	# 1T
M4.0 x 0.70	103.00	206.00	18.00	# 1T
M5.0 x 0.80	103.00	206.00	18.00	# 1T
M6.0 x 1.00	94.00	188.00	18.00	# 1T
M8.0 x 1.25	94.00	188.00	18.00	# 2T
M10 x 1.00	102.00	204.00	18.00	# 3T
M10 x 1.25	102.00	204.00	18.00	# 3T
M10 x 1.50	102.00	204.00	18.00	# 3T
M12 x 1.25	104.00	208.00	18.00	# 3T
M12 x 1.50	108.00	216.00	18.00	# 3T
M12 x 1.75	108.00	216.00	18.00	# 3T
M14 x 1.50	120.00	240.00	24.00	# 4T
M14 x 2.00	120.00	240.00	24.00	# 4T
M16 x 1.50	120.00	240.00	24.00	# 4T
M16 x 2.00	120.00	240.00	24.00	# 4T
M18 x 1.50	160.00	320.00	24.00	# 4T
M18 x 2.50	173.00	346.00	24.00	# 4T
M20 x 1.00	200.00	400.00	24.00	# 4T
M20 x 1.50	198.00	396.00	24.00	# 4T
M20 x 2.50	198.00	396.00	24.00	# 4T
M22 x 1.50	198.00	396.00	28.00	# 5T





Penroyer-Dodge Co.

Metric Truncated Setting Plug Gages

American Gage Design / Short & Long Form Calibration Reports Available

How To Order

1. State Quantity desired.
2. Nominal metric size and metric threads per inch and class of fit.
Example: 10.00 x 1.25-6g
3. Go or Not Go or a complete double end.
4. Handles: Either single end or double end. Handles ordered in colors other

Call Toll Free
1-800-736-4243

- than Red or Green add \$15.00 per handle.
5. Special marking may be added for an additional charge. (\$12.00 min).
6. Short Form c of c @ n/c. Long Form Calibration Reports add \$16.00 per member.
7. Calibration stickers available @ \$3.50 per sticker (advise calibration cycle).
8. W-tolerance P.D.: Add 30% to each member.
9. Full Form set plugs available upon request.
10. For "MJ Series", price on application.

CLASS X RIGHT HAND
METRIC SETTING PLUG GAGES
W-TOL ON LEAD & ANGLE

Nominal Size	Go or Not Go 6H Members	Complete Double End Gage w/Handle	Handle Only	Handle Size
M1.6 x 0.35	100.00	211.00	11.00	# 000
M2.0 x 0.40	90.00	191.00	11.00	# 000
M2.5 x 0.45	90.00	191.00	11.00	# 000
M3.0 x 0.50	89.00	189.00	11.00	# 00
M3.5 x 0.60	89.00	189.00	11.00	# 00
M4.0 x 0.70	86.00	183.00	11.00	# 0
M5.0 x 0.80	86.00	183.00	11.00	# 0
M6.0 x 1.00	78.00	167.00	11.00	# 0
M8.0 x 1.25	78.00	167.00	11.00	# 1
M10 x 1.00	83.00	177.00	11.00	# 2
M10 x 1.25	83.00	177.00	11.00	# 2
M10 x 1.50	83.00	177.00	11.00	# 2
M12 x 1.25	86.00	183.00	11.00	# 2
M12 x 1.50	86.00	183.00	11.00	# 2
M12 x 1.75	86.00	183.00	11.00	# 2
M14 x 1.50	98.00	207.00	11.00	# 3
M14 x 2.00	98.00	207.00	11.00	# 3
M16 x 1.50	98.00	207.00	11.00	# 3
M16 x 2.00	98.00	207.00	11.00	# 3
M18 x 1.50	105.00	221.00	11.00	# 3
M18 x 2.50	110.00	231.00	11.00	# 3
M20 x 1.00	120.00	251.00	11.00	# 3
M20 x 1.50	117.00	245.00	11.00	# 3
M20 x 2.50	117.00	245.00	11.00	# 3
M22 x 1.50	150.00	311.00	11.00	# 4





Pennoyer-Dodge Co.

NPTF Taper Pipe Ring & Plug Gages

American Gage Design / Short & Long Form Calibration Reports Available

How To Order

1. State Quantity desired.
2. Nominal size and L-1, L-2, or plain taper for ring gages and L-1, L-3, or plain taper for plug gages.
Example: 1/16-27 NPTF L-2 RING
3. Handles: Either single end or double end. Handles ordered in colors other

Call Toll Free
1-800-736-4243

- than Red or Green add \$15.00 each per handle.
4. Special marking for an additional charge, (\$12.00 min.)
 5. NPTF plugs come with one basic step. If MN and /or MX steps desired, add \$30.00 per each additional step 1/16-27 to 1 1/2, Above 1 1/2, \$45.00.
 6. Short Form c of c @ n/c. Long Form Calibration Reports add \$16.00 per member.
 7. Calibration stickers available @ \$3.50 per sticker (advise calibration cycle).

NPTF TAPER PIPE THREAD GAGES

Nominal Size	L-1 Ring Gage	L-2 Ring Gage	Plain Taper Ring Gage	L-1 Plug Gage	L-3 Plug Gage	Plain Taper Plug Gage	Handle Only	Handle Size
1/16-27	275.00	321.00	308.00	102.00	133.00	182.00	11.00	# 1
1/8-27	245.00	321.00	308.00	81.00	92.00	182.00	11.00	# 2
1/4-18	240.00	330.00	308.00	84.00	105.00	182.00	11.00	# 3
3/8-18	250.00	330.00	308.00	104.00	120.00	188.00	11.00	# 3
1/2-14	265.00	345.00	308.00	118.00	133.00	198.00	11.00	# 4
3/4-14	290.00	367.00	343.00	130.00	145.00	205.00	11.00	# 4
1 - 11.5	315.00	409.00	391.00	145.00	160.00	230.00	12.00	# 5
1 1/4 - 11.5	373.00	460.00	440.00	157.00	174.00	242.00	12.00	# 5
1 1/2 - 11.5	391.00	490.00	475.00	182.00	195.00	248.00	12.00	# 5
2 - 11.5	480.00	573.00	536.00	216.00	230.00	298.00	12.00	# 5
2 1/2 - 8	545.00	683.00	599.00	332.00	342.00	450.00	19.00	# 6
3 - 8	597.00	806.00	753.00	382.00	395.00	498.00	19.00	# 6



NOTE:

Master gages for NPT working gages are L-1 design.

Master gages for NPTF working gages are special design to encompass the L-1 and L-3 length for the master ring and the L-2 and L-3 length on the master plug. A set consists of (1) master plug and (1) master ring.

MIL-P-7105B and SAE-AS-71051 does not specify design on ANPT master. Pennoyer-Dodge Co. designs these masters the same as the NPTF.



Penroyer-Dodge Co.

ANPT Taper Pipe Ring & Plug Gages

American Gage Design / Short & Long Form Calibration Reports Available

How To Order

1. State Quantity desired.
2. Nominal size and L-1, L-2, or plain taper for ring gages and L-1, L-3, or plain taper for plug gages.
Example: 1/16-27 ANPT L-1 RING
3. Handles: Either single end or double end. Handles ordered in colors other

Call Toll Free
1-800-736-4243

4. than Red or Green add \$15.00 each per handle.
4. Special marking for an additional charge, (\$12.00 min.)
5. ANPT plugs come with three steps, Basic, MN and MX .
6. Short Form c of c @ n/c. Long Form Calibration Reports add \$16.00 per member.
7. Calibration stickers available @ \$3.50 per sticker (advise calibration cycle).

ANPT TAPER PIPE THREAD GAGES

Nominal Size	L-1 Ring Gage	L-2 Ring Gage	Plain Taper Ring Gage	L-1 Plug Gage	L-3 Plug Gage	Plain Taper Plug Gage	Handle Only	Handle Size
1/16-27	275.00	326.00	316.00	139.00	160.00	182.00	11.00	# 1
1/8-27	245.00	326.00	316.00	135.00	155.00	182.00	11.00	# 2
1/4-18	240.00	330.00	316.00	135.00	155.00	182.00	11.00	# 3
3/8-18	250.00	330.00	316.00	135.00	155.00	188.00	11.00	# 3
1/2-14	265.00	345.00	316.00	144.00	162.00	198.00	11.00	# 4
3/4-14	290.00	387.00	351.00	156.00	175.00	205.00	11.00	# 4
1 - 11.5	315.00	419.00	391.00	170.00	190.00	230.00	12.00	# 5
1 1/4 - 11.5	373.00	468.00	440.00	202.00	204.00	242.00	12.00	# 5
1 1/2 - 11.5	391.00	492.00	475.00	208.00	225.00	248.00	12.00	# 5
2" - 11.5	480.00	586.00	536.00	243.00	261.00	312.00	12.00	# 5
2 1/2 - 8	545.00	697.00	599.00	371.00	363.00	470.00	19.00	# 6
3" - 8	669.00	823.00	753.00	444.00	444.00	521.00	19.00	# 6



NOTE:

Master gages for NPT working gages are L-1 design.

Master gages for NPTF working gages are special design to encompass the L-1 and L-3 length for the master ring and the L-2 and L-3 length on the master plug. A set consists of (1) master plug and (1) master ring.

MIL-P-7105B and SAE-AS-71051 does not specify design on ANPT master. Penroyer-Dodge Co. designs these masters the same as the NPTF.



Penroyer-Dodge Co.

NPT Taper Pipe Ring & Plug Gages

American Gage Design / Short & Long Form Calibration Reports Available

How To Order

1. State Quantity desired.
2. Nominal size and L-1 for ring gages or for plug gages.
Example: 1/16-27 NPT L-1 RING or 1/16-27 NPT L-1 PLUG
3. Handles: Either single end or double end. Handles ordered in colors other than Red or Green add \$15.00 each per handle.

Call Toll Free
1-800-736-4243

4. Special marking for an additional charge, (\$12.00 min.)
5. NPT plugs come with one basic step. If MN and /or MX steps desired, add \$30.00 per each additional step 1/16-27 to 1 1/2, Above 1 1/2, \$45.00.
6. Short Form c of c @ n/c. Long Form Calibration Reports add \$16.00 per member.
7. Calibration stickers available @ \$3.50 per sticker (advise calibration cycle).

NPT TAPER PIPE THREAD GAGES

Nominal Size	L-1 Ring Gage	L-1 Plug Gage	Handle Only	Handle Size
1/16-27	275.00	90.00	11.00	# 1
1/8-27	225.00	65.00	11.00	# 2
1/4-18	235.00	68.00	11.00	# 3
3/8-18	245.00	75.00	11.00	# 3
1/2-14	265.00	83.00	11.00	# 4
3/4-14	285.00	94.00	11.00	# 4
1-11.5	310.00	105.00	12.00	# 5
1 1/4 - 11.5	373.00	119.00	12.00	# 5
1 1/2 - 11.5	391.00	132.00	12.00	# 5
2 - 11.5	480.00	160.00	12.00	# 5
2 1/2 - 8	545.00	193.00	19.00	# 6
3 - 8	597.00	225.00	19.00	# 6
3 1/2 - 8	821.00	355.00	19.00	# 7
4 - 8	1007.0	421.00	19.00	# 7
5 - 8	1176.0	530.00	19.00	# 7
6 - 8	1380.0	617.00	19.00	#7



NOTE:

Master gages for NPT working gages are L-1 design.

Master gages for NPTF working gages are special design to encompass the L-1 and L-3 length for the master ring and the L-2 and L-3 length on the master plug. A set consists of (1) master plug and (1) master ring.

MIL-P-7105B and SAE-AS-71051 does not specify design on ANPT master. Penroyer-Dodge Co. designs these masters the same as the NPTF.



Pennoyer-Dodge Co. Cylindrical Taperlock Gages

American Gage Design / Short & Long Form Calibration Reports Available

How To Order

1. State Quantity desired.
2. Nominal decimal size and tolerance class.
Examples: .1500 class XX Go member, .1500 XX Go S.E.,
.1500 - .1509 XX D.E. Gage.
3. Go or Not Go or a complete double end.
4. Handles, either single end or double end. Handles ordered in colors other than Red or Green add \$15.00 per handle.

5. Special marking may be added for an additional charge. (\$12.00 min).
6. Short Form certifications N/C. Long Form Calibration Reports add \$16.00 per member.
7. Calibration stickers available @ \$3.50 per sticker (advise calibration cycle).
8. CHROME: Add 30% to each member.

**Call Toll Free
1-800-736-4243**

CYLINDRICAL TAPERLOCK GAGES

Nominal Size		Go Class XX Members	Not Go Class XX Members	Go & Not Go D.E. Class XX W/Handle	Go Class X Members	Not Go Class X Members	Go & Not Go D.E. Class X W/Handle	Go Class Y & Z Members	Not Go Class Y & Z Members	Go & Not Go D.E. Class Y & Z W/Handle	Handle Only
Above	To & Incl										
0.059 (1.499mm)	0.105 (2.667mm)	56.00	55.00	122.00	48.00	47.00	106.00	45.00	44.00	100.00	11.00
0.105 (2.667mm)	0.150 (3.810mm)	56.00	55.00	122.00	48.00	47.00	106.00	45.00	44.00	100.00	11.00
0.150 (3.810mm)	0.230 (5.842mm)	56.00	55.00	122.00	48.00	47.00	106.00	45.00	44.00	100.00	11.00
0.230 (5.842mm)	0.510 (12.954mm)	57.00	56.00	124.00	50.00	48.00	109.00	47.00	45.00	103.00	11.00
0.510 (12.954mm)	0.825 (20.955mm)	62.00	61.00	134.00	53.00	50.00	114.00	50.00	48.00	109.00	11.00
0.825 (20.955mm)	1.135 (28.829mm)	69.00	67.00	147.00	62.00	61.00	134.00	60.00	58.00	129.00	11.00
1.135 (28.829mm)	1.510 (38.354mm)	71.00	68.00	151.00	65.00	63.00	140.00	61.00	60.00	133.00	12.00





Pennoyer-Dodge Co. Cylindrical Reversible Gages

American Gage Design / Short & Long Form Calibration Reports Available

How To Order

1. State Quantity desired.
2. Nominal decimal size and tolerance class and Go, Not Go or Master.
Examples: .1500 class XX Go member, .1500 XX Go S.E.,
.1500 - .1509 XX D.E. Gage.
3. Types: Go, Not Go or Master, single end or a complete double end.
4. Handles: Either single end or double end. Handles ordered in colors other than Red or Green collets and other than plain handles, call for current pricing.
5. Special marking may be added for an additional charge. (\$12.00 min).
6. Short Form c of c @ n/c. Long Form calibration report add \$16.00 per member.

7. Calibration stickers available @ \$3.50 per sticker (advise calibration cycle).
8. All pin style above 1.010, price upon application.
9. CHROME: Add 50% to each member. Sizes < .080, price upon application.
10. XXX gages price upon application, on sizes .125 and larger.
11. Use Z prices shown below for inch sizes in thousand and half thousand sizes, and two decimal places metric sizes. Z pin sizes other than this use X & Y pricing. Standard pin length is two inches.
12. Extra length gages available, price on application.

**Call Toll Free
1-800-736-4243**

CYLINDRICAL REVERSIBLE GAGES

Nominal Size		Class XX Members	Class XX D.E.	Class X & Y Members	Class X & Y D.E.	Class Z Members	Class Z D.E.	Handle Only
Above	To & Incl							
.035 (0.889mm)	.075 (1.905mm)	47.00	109.00	40.00	95.00	37.00	89.00	15.00
.075 (1.905mm)	.180 (4.572mm)	45.00	105.00	37.00	89.00	35.00	85.00	15.00
.180 (4.572mm)	.510 (12.954mm)	45.00	108.00	37.00	92.00	35.00	88.00	18.00
.510 (12.954mm)	.760 (19.304mm)	48.00	118.00	40.00	102.00	37.00	96.00	22.00
.760 (19.304mm)	1.010 (25.654mm)	68.00	163.00	58.00	143.00	55.00	137.00	27.00



Handle Size	Above	To & Including
1w	.030	.075
2w	.075	.180
3w	.180	.281
4w	.281	.406
5w	.406	.510
6w	.510	.635
7w	.635	.760
8w	.760	1.010



Pennoyer-Dodge Co. Cylindrical Trilock Gages

American Gage Design / Short & Long Form Calibration Reports Available

How To Order

1. State Quantity desired.
2. Nominal decimal size and tolerance class class and Go, Not Go or Master.
Examples: .1500 class XX Go member, .1500 XX Go S.E.,
.1500 - .1509 XX D.E. Gage.
3. Go or Not Go or a complete double end.
4. Handles: Either single end or double end. Handles ordered in colors other than Red or Green add \$15.00 per handle.

5. Special marking may be added for an additional charge. (\$12.00 min).
6. Short Form c of c @ n/c. Long Form Calibration Reports add \$16.00 per member.
7. Calibration stickers available @ \$3.50 per sticker (advise calibration cycle).
8. All trilock style from .760 up to and including 1.500 price upon application.
9. CHROME: Add 30% to each member.
10. XXX gages quoted upon request.

**Call Toll Free
1-800-736-4243**

CYLINDRICAL TRILOCK GAGES

Nominal Size		Go Class XX Members	Not Go Class XX Members	Go & Not Go Class XX W/Handle	Go Class X Members	Not Go Class X Members	Go & Not Go Class X W/Handle	Go Class Y & Z Members	Not Go Class Y & Z Members	Go & Not Go Class Y & Z W/Handle	Handle Only
Above	To & Incl										
1.510 (38.354mm)	1.760 (44.704mm)	105.00	94.00	218.00	93.00	90.00	202.00	90.00	87.00	196.00	19.00
1.760 (44.704mm)	2.010 (51.054mm)	105.00	94.00	218.00	93.00	90.00	202.00	90.00	87.00	196.00	19.00
2.010 (51.054mm)	2.260 (57.404mm)	119.00	104.00	242.00	102.00	99.00	220.00	93.00	88.00	200.00	19.00
2.260 (57.404mm)	2.510 (63.754mm)	119.00	104.00	242.00	102.00	99.00	220.00	93.00	88.00	200.00	19.00
2.510 (63.754mm)	2.760 (70.104mm)	136.00	117.00	272.00	120.00	104.00	243.00	102.00	92.00	213.00	19.00
2.760 (70.104mm)	3.010 (76.454mm)	136.00	117.00	272.00	120.00	104.00	243.00	102.00	92.00	213.00	19.00
3.010 (76.454mm)	3.260 (82.804mm)	196.00	160.00	375.00	170.00	147.00	336.00	150.00	127.00	296.00	19.00
3.260 (82.804mm)	3.510 (89.154mm)	196.00	160.00	375.00	170.00	147.00	336.00	150.00	127.00	296.00	19.00





Pennoyer-Dodge Co. Cylindrical Progressive Gages

American Gage Design / Short & Long Form Calibration Reports Available

How To Order

1. State Quantity desired.
2. Nominal decimal size and tolerance class and Go, Not Go or Master.
Examples: .1500 class XX Go member, .1500 XX Go S.E.,
.1500 - .1509 XX D.E. Gage.
3. Handles: Either single end or double end. Handles ordered in colors other than Red or Green add \$15.00 per handle.
4. Special marking may be added for an additional charge. (\$12.00 min).
5. Short Form c of c @ n/c. Long Form Calibration Reports add \$32.00 per member.
6. Calibration stickers available @ \$3.50 per sticker (advise calibration cycle).
7. CHROME: Add 30% to each member.

**Call Toll Free
1-800-736-4243**

CYLINDRICAL PROGRESSIVE GAGES

Nominal Size		Class XX Members	Class X Members	Class Y & Z Members	Handle Only
Above	To & Incl				
.059 (1.499mm)	.105 (2.667mm)	104.00	87.00	80.00	11.00
.105 (2.667mm)	.150 (3.810mm)	95.00	87.00	79.00	11.00
.150 (3.810mm)	.185 (4.699mm)	95.00	87.00	79.00	11.00
.185 (4.699mm)	.230 (5.842mm)	95.00	87.00	78.00	11.00
.230 (5.842mm)	.365 (9.271mm)	95.00	87.00	78.00	11.00
.365 (9.271mm)	.510 (12.954mm)	97.00	87.00	82.00	11.00
.510 (12.954mm)	.635 (16.129mm)	103.00	89.00	83.00	11.00
.635 (16.129mm)	.760 (19.304mm)	104.00	90.00	85.00	11.00
.760 (19.304mm)	.825 (20.955mm)	107.00	90.00	85.00	11.00
.825 (20.955mm)	1.135 (28.829mm)	116.00	99.00	90.00	11.00
1.135 (28.829mm)	1.510 (38.354mm)	127.00	105.00	93.00	12.00





Pennoyer-Dodge Co. Cylindrical Ring Gages

American Gage Design / Short & Long Form Calibration Reports Available

How To Order

1. State Quantity desired.
2. Nominal decimal size and tolerance class.
Example: .150 class XX
3. Go or Not Go or a Master ring.
4. Special marking may be added for an additional charge. (\$12.00 min).
5. Short Form c of c @ n/c. Long Form Calibration Reports add \$16.00 per ring.

6. Calibration stickers available @ \$3.50 per sticker (advise calibration cycle).
7. CHROME: Add 50% per ring for .125 and up.
8. XXX Master rings quoted upon request.

**Call Toll Free
1-800-736-4243**

CYLINDRICAL RING GAGES

Above	Nominal Size To & Incl	Class XX Members	Class X Members	Class Y & Z Members
.062 (1.575mm)	.070 (1.778mm)	150.00	126.00	124.00
.070 (1.778mm)	.090 (2.286mm)	137.00	117.00	111.00
.090 (2.286mm)	.150 (3.810mm)	137.00	117.00	111.00
.150 (3.810mm)	.230 (5.842mm)	106.00	99.00	95.00
.230 (5.842mm)	.365 (9.271mm)	97.00	90.00	89.00
.365 (9.271mm)	.510 (12.954mm)	99.00	93.00	90.00
.510 (12.954mm)	.825 (20.955mm)	104.00	98.00	95.00
.825 (20.955mm)	1.135 (28.829mm)	114.00	105.00	103.00
1.135 (28.829mm)	1.510 (38.354mm)	133.00	118.00	112.00
1.510 (38.354mm)	2.010 (51.054mm)	156.00	145.00	141.00
2.010 (51.054mm)	2.510 (63.754mm)	195.00	180.00	170.00
2.510 (63.754mm)	3.010 (76.454mm)	230.00	205.00	197.00
3.010 (76.454mm)	3.510 (89.154mm)	265.00	238.00	227.00
3.510 (89.154mm)	4.010 (101.854mm)	305.00	280.00	255.00
4.010 (101.854mm)	4.760 (120.904mm)	345.00	305.00	288.00
4.760 (120.904mm)	5.510 (139.954mm)	455.00	390.00	355.00



PRICES SUBJECT TO CHANGE WITHOUT NOTICE 7/1/2012

- 28



Pennoyer-Dodge Co.

Gage Re-Calibration Charges

The following "**Standard Published**" prices are for calibration of customer submitted thread plugs; thread rings; pipe plugs and rings; and cylindrical plug and rings **regardless of calibration results**. Expedited, safety related and Special Calibration charges are priced on application and will not be waived, regardless of the calibration results.

Pennoyer-Dodge Co. also manufacture's and/or calibrates many other types of gages. Please call/fax your inquiries.

Calibration of gages in accordance to ISO 10012-1, ANSI/NCSL Z540-1, Mil-Std-45662A. Minimum order is \$50.00

THREAD PLUGS (PER MEMBER)	STANDARDS	SET PLUGS	PIPE	SIX STEP
ANY SIZE 60 DEGREE & METRIC'S FROM # 0 THUR 3"	18.00	28.00	43.00	48.00
OVER 3" TO 6"	25.00	38.00	CALL	CALL
OVER 6" and High/Low	CALL FOR CURRENT PRICING	CALL FOR CURRENT PRICING	CALL FOR CURRENT PRICING	CALL FOR CURRENT PRICING

THREAD RINGS (PER RING)	STANDARDS	PIPE	SIX STEP
STANDARD UNC, UNF AND UNEF FROM # 0 TO 1 1/2"	28.00	48.00	50.00
STANDARDS ABOVE 1 1/2" TO 3" AND SPECIALS UP TO 3" (60 DEGREE)	48.00	63.00	65.00
OVER 3" (60 DEGREE)	CALL FOR CURRENT PRICING	CALL FOR CURRENT PRICING	CALL FOR CURRENT PRICING

CYLINDRICAL PLUGS	PER MEMBER
UP TO .020	CALL FOR CURRENT PRICING
Above .020 THRU 5.00	18.00
OVER 5.00	CALL FOR CURRENT PRICING
FOR XXX TOL. CALIBRATION	CALL FOR CURRENT PRICING

CYLINDRICAL RINGS	PER MEMBER
.059 THRU .125	48.00
Above .125 THRU 4.010	28.00
Above 4.010 THRU 6.010	43.00
OVER 6.010	CALL FOR CURRENT PRICING
FOR XXX TOL. CALIBRATION	CALL FOR CURRENT PRICING

PRICES SUBJECT TO CHANGE WITHOUT NOTICE 7/1/2012

- 29



Pennoyer-Dodge Co.

Special Gage Listing

Special Precision Gages Now Manufactured by

Pennoyer-Dodge Company

PLUG GAGES - THREAD

Standard 60° N.F., N.C.,
UNC, UNF, UNJ, UNJF,
NEF, UNEF
Setting "X" and "W" tol.
S.T.I. "X" and "W" tol.
Acme 29° Stub & Trapezoidal
Threads
Buttress Threads
Metric Threads
Whitworth 55°
Stright Pipe,
NPSC, NPSF, NPSI, NPSM,
NPSL
Taper Pipe, NPT, NPTF,
ANPT, BSP
Taper Pipe, Setting
British Pipe Threads
Taper Threads
Square Threads
A N Port
M S Threads
Hose Fittings
Position Gages

RING GAGES- THREAD

Metric
60° N.F., N.C., UNC, UNJ,
UNJF, NEF & UNEF
Acme
Buttress
Whitworth 55°
Straight Pipe, NPSC, NPSF,
NPSI, NPSM, NPSL
Taper Pipe, NPT, NPTF, ANPT,
BSP
British Pipe
Taper
Square

VARIABLE GAGING - INTER- NAL & EXTERNAL

Trirolls
Internal Thread Comparator

SNAP GAGES

Plain Adjustable
Built-up
Fixed Solid
Special Indicating
Roll Thread to Mil-Std-8879A and
Mil-Std-7742A, Amendment No. 1
Methods A and B.

AIR GAGE TOOLING

Air Ring
Air Probe
Related Masters

OIL FIELD GAGES

Sucker Rod
Casing
Tubing
Line Pipe
Rotary

PLUG GAGES - PLAIN CYLINDRICAL

Flat, hex, & Square
Progressive Type
Plain Taper (Master) Brown &
Sharpe, Luer Gages, etc.
Morse or any Special Taper to
Print.
Plain Cylindrical, Taperlock, Re-
versible, Trilock
M S
Master Disks Style 1,2 & 3
Paddle Type
Depth
M S Flush
Flush Pin
Functional
A N Port
Thread Measuring Wires

RING GAGES -

PLAIN CYLINDRICAL

Plain, Go, Not Go, Master Setting
Taper
Progressive

SPECIAL TOOLING

Hole Location Gages
Drill Fixtures
Milling Fixtures
Mandrils
Template Gages
Spanner Gages
Receiver Gages
Fixture Gages
Functional Gages
Concentricity & Runout Gages
Profile Gages
Crimping Tool Gages
Flush Pin Gages
Paddle Gages
Chamber Gages

SPECIAL SERVICES

Certification on all types of Gages
listed, traceable to N.I.S.T.
Lead Screws
Thread Grinding to close toleranc-
es.
Jig Grinding
Lap I.D. and O.D. Parts to close
tolerances.
Lapping of Plugs and Rings -
Both Plain and Threads.



Pennoyer-Dodge Co.

Accurate Formula To Compute The Pitch And Major/Minor Diameters For Before Plate Thread Plugs And Thread Rings*

If no plating tolerance is given, then it is assumed that the maximum plating thickness will be nominal or minimum thickness given plus 50%. (see ASME B1.1-1989, pg. 16, 7.4.2; pg. 18, 7.5.2) The diameters of the gaging for external threads will be smaller while the diameters of the gaging for internal threads will be larger, than standard.

If no plating tolerance is given, then it is assumed that the maximum plating thickness will be nominal or minimum thickness given plus 50%. (see ASME B1.1-1989, pg. 16, 7.4.2; pg. 18, 7.5.2) The diameters of the gaging for external threads will be smaller while the diameters of the gaging for internal threads will be larger, than standard.

THREAD PLUGS

For the Go plug pitch diameter, **add** the **MAX.** amount of plate. For the Not Go pitch diameter, **add** the **MIN.** amount of plate. For the majors of work plugs, **increase** the major diameter on Go work plug by using half the **MAX.** amount of plate. On Not Go work plugs, **increase** the major diameter by using half the **MIN.** amount of plate.

Example

Based on .0002 to .0003 allowance per side (multiply by 4)
 .0002 X 4 = .0008 **MIN.**
 .0003 X 4 = .0012 **MAX.**
 1/4-28 UNF 2B B/P
Basic GO P.D. .2268 + .0012 **MAX.** = .2280 Go P.D.
Basic NOT GO P.D. .2311 + .0008 **MIN.** = .2319 Not Go P.D.
Basic GO major .2500 + (.0012 / 2) = .2506 B/P Go major.
Basic NOT GO major .2466 + (.0008 / 2) = .2470 B/P Not Go major.

THREAD RINGS

For the Go ring, **subtract** the **MAX.** amount of plate. For the Not Go ring, **subtract** the **MIN.** amount of plate. For the minors of thread rings, **decrease** the minor diameter on the Go thread ring by using half the **MAX.** amount of plate. On Not Go thread rings, **decrease** the minor diameter by using half the **MIN.** amount of plate.

Example

Based on .0002 to .0003 allowance per side (multiply by 4)
 .0002 X 4 = .0008 **MIN.** .0003 X 4 = .0012 **MAX.**
 1/4-28 UNF 2A B/P
Basic GO P.D. .2258 - .0012 **MAX.** = .2246 Go P.D.
Basic NOT GO P.D. .2225 - .0008 **MIN.** = .2217 Not Go P.D.

Basic GO minor .2103 - (.0012 / 2) = .2097 B/P Go minor.
Basic NOT GO minor .2148 - (.0008 / 2) = .2144 B/P Not Go minor.

* In accordance with ANSI/ASME B1.1-1989

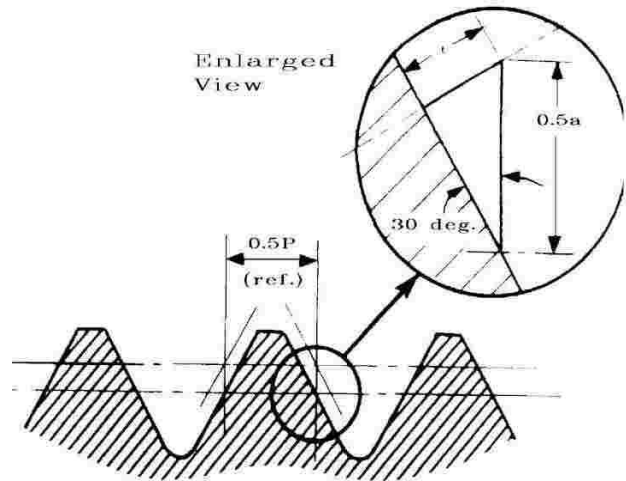

RATIO OF PITCH DIAMETER CHANGE TO THICKNESS OF COATING (60° ONLY)

t = thickness of coating
 a = pitch diameter change due to coating

0.25a = t and a = 4t or the pitch diameter of a 60° thread changes by four times the thickness of the coating

BEFORE PLATING RATIOS

- 60° thread = 4:1
- 29° Acme = 8:1
- 7°-45° Buttress = 4.3138:1
- 14° 30'-5° Buttress = 11.9311:1
- 10° Square thread = 23:1

PENNOYER-DODGE CO.

introduces

"TWIST'ER GAGES"



MMC

RFC

LMC



SPC

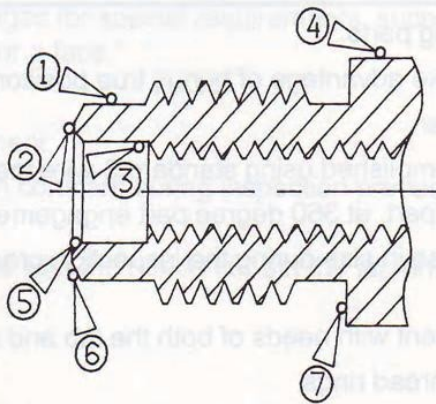

Functional Location - P.D. Limit & Size

"When you want it Right...and Right away"



Pennoyer-Dodge Co.

“ TWISTER OUT ”

YOUR CHOICE FOR FUNCTIONAL THREADED AXIS LOCATION, REGARDLESS OF FEATURE SIZE

“TWISTER OUT” RING PRINCIPLE:

The “TWISTER OUT” ring with its P.D. related ground O.D. and faces, works by two independent thread gage sections that, when twisted, grips the flanks of the product thread. This locks and locates the functional thread axis of the product thread. At this point a variety of inspection techniques are possible, such as true position, runout, and concentricity to the part functional P.D. datum.

“TWISTER OUT” RING FEATURES:

- Reliable functional pitch diameter datum source for location of functional thread axis position.
- Accuracy to .0001
- No complicated moving parts.
- Easily adapted for SPC.
- Use of high quality tool steel (**Chrome also** available).
- Engineered and manufactured in the U.S.A.

“TWISTER OUT” RING ADVANTAGES:

- Allows part manufacturer to accurately determine runout, perpendicularity, true position, and concentricity of part parameters to the P.D. RFS EXAMPLE:

	Ø.005	P.D.
--	-------	------
- Inspects functional thread plug gages for special requirements, such as: “Pitch diameter of gages must run within .0002 to centers, or a face.”
- Assures assimilability
- Checks 360 degree part engagement.
- Major and minor diameters remain constant during inspection process as compared to alternate types of gaging.
- Portability and accuracy consistent with the needs of both the lab and manufacturing environment

Prices available upon application

PRICES SUBJECT TO CHANGE WITHOUT NOTICE 7/1/2012

- 33



Pennoyer-Dodge Co.

“ TWISTER IN ”

YOUR CHOICE FOR PRECISION THREAD LOCATION AND FUNCTIONAL SIZE

“TWISTER IN” PLUG PRINCIPLE:

The “TWISTER ” plug works by movable thread gage segments that engage one flank angle, while the thread body engages the opposite thread flank angle of the product thread. The resultant “flank grip” establishes the functional size and/or functional thread axis of the part, depending on how the twister plug is fabricated.

“TWISTER IN” PLUG FEATURES:

- Reliable functional pitch diameter datum source for functional size determination and/or functional thread axis location.
- Accuracy to .0001
- No complicated moving parts.
- Easily adapted for SPC.
- Consistent readings.
- Locks readings in place.
- Use of high quality tool steel (**Chrome also** available).
- Engineered and manufactured in the U.S.A.

“TWISTER IN” PLUG ADVANTAGES:

- Allows part manufacturer to take advantage of bonus true position part tolerancing

\oplus	$\varnothing.005$	\textcircled{M}	P.D.
----------	-------------------	-------------------	------
- **No need** for solid ring set master.
- Assures assimilability
- Can measure functional size of part, at 360 degree part engagement.
- Major diameter does not increase in size during the inspection process , as compared to alternate types of gages.
- Portability and accuracy consistent with the needs of both the lab and manufacturing environment
- Calibrate adjustable and solid thread rings.

Prices available upon application

PRICES SUBJECT TO CHANGE WITHOUT NOTICE 7/1/2012

- 34

STANDARD GAGING

Pennoyer-Dodge Company has one of the largest selections of standard and **special** gages in stock. In many instances they are available for immediate delivery.

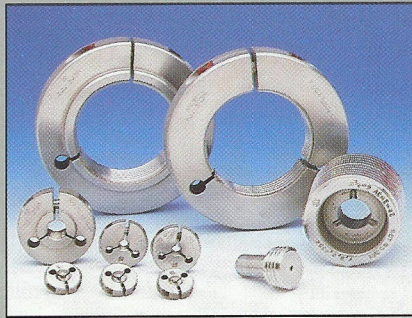

CERTIFICATION OPTIONS

1. Short Form Certificate of Conformance - No Charge
2. Long Form Certifications with actual dimensions available at nominal charge.

All gages are hand lapped for longer wear.

All gages are certified in accordance to MIL-STD-45662A and are traceable to the N.I.S.T.

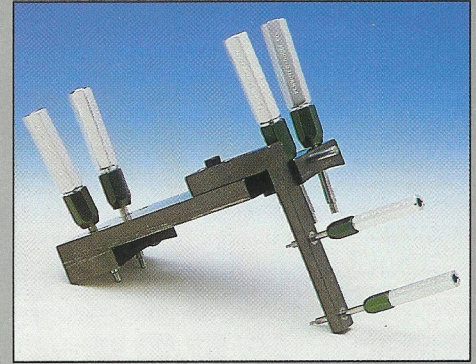
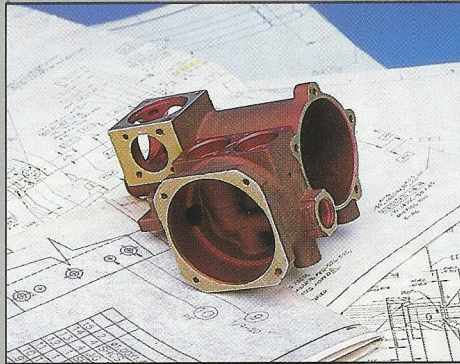

CUSTOM ENGINEERING AND SPECIAL TOOLING

- **Fabrication** of custom gages to existing gage drawings.
- **Design and fab** capabilities from concept to completion per ANSI Y14.5.
- As a leader in the design and production of Functional Gages, we are familiar with the problems of the manufacturing industry. We invite you to request our services regardless of your R & D or engineering needs. We can design a new gage, or develop a less costly method to meet your present gaging needs.

OTHER SERVICES

- Parts analysis and "troubleshooting".
- Contract Jig Grinding with open machine time available.
- Custom Lapping.
- Special Thread Grinding.

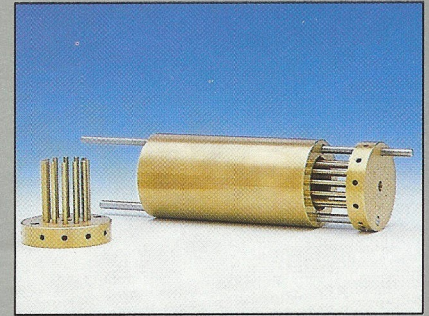

"When you want it right ... and right away" - Call...

PENNOYER-DODGE COMPANY, GLENDALE, CA.

CALL TOLL FREE 1-800-PEN-GAGE FAX: (818) 240-5719 (213) 245-8971 (818) 240-1170

INDUSTRIES SERVED

- AEROSPACE
- AIRCRAFT
- AUTOMOTIVE
- COMMERCIAL APPLICATION
- COMPUTER
- DEFENSE
- ELECTRONICS
- MEDICAL
- NUCLEAR
- OIL FIELD
- ORDINANCE

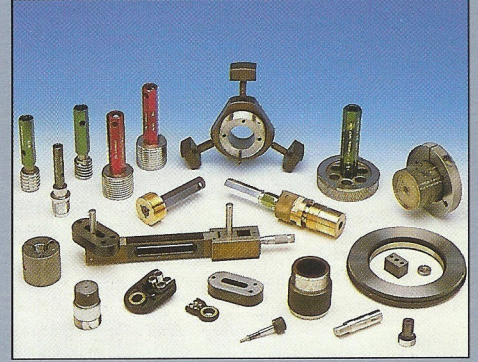
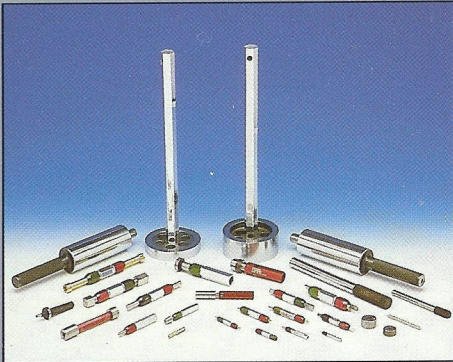

PRODUCTS AND SERVICES AVAILABLE

THREAD PLUG GAGES
 THREAD RING GAGES
 THREAD SETTING PLUGS
 REVERSIBLE THREAD GAGES
 S.T.I. THREAD GAGES
 OIL COUNTRY GAGES
 TAPERED PIPE GAGES
 METRIC GAGES
 ACME GAGES
 BUTTRESS GAGES
 WHITWORTH GAGES
 SQUARE THREADS
 BRITISH PIPE GAGES
 VARIABLE GAGING

CYLINDRICAL PLUG GAGES
 CYLINDRICAL RING GAGES
 PROGRESSIVE PLUG GAGES
 PIN TYPE GAGES
 MASTER DISKS
 PROFILE GAGES
 M.S. PLUG GAGES
 A.N. PORT PLUG GAGES
 HOSE FITTING GAGES
 PADDLE GAGES
 LEUR GAGES
 AIR PLUGS AND PROBES
 MANDRILS

FIXTURE GAGES
 FLUSH PIN GAGES
 CONCENTRICITY GAGES
 TRUE POSITION GAGES
 RADIUS GAGES
 RECEIVER GAGES
 TEMPLATE GAGES
 CRIMPING TOOL GAGES
 ROLL THREAD SNAP GAGES
 (ALSO CONE & V)
 CUSTOM LAPPING
 LEAD SCREWS
 SPECIAL THREAD GRINDING
 CONTRACT JIG GRINDING

"When you want it right ... and right away"

PENNOYER-DODGE COMPANY
 6634 SAN FERNANDO ROAD
 GLENDALE, CALIFORNIA 91201



CALL

Our New Number

(818) 547-2100 • FAX (818) 240-5719
 6650 SAN FERNANDO ROAD
 GLENDALE, CA 91201-1017
 TOLL FREE (800) 736-4243